

**Section A-A ( Scale 1 :05 )**

**Detail B ( Scale 1 : 2 )**

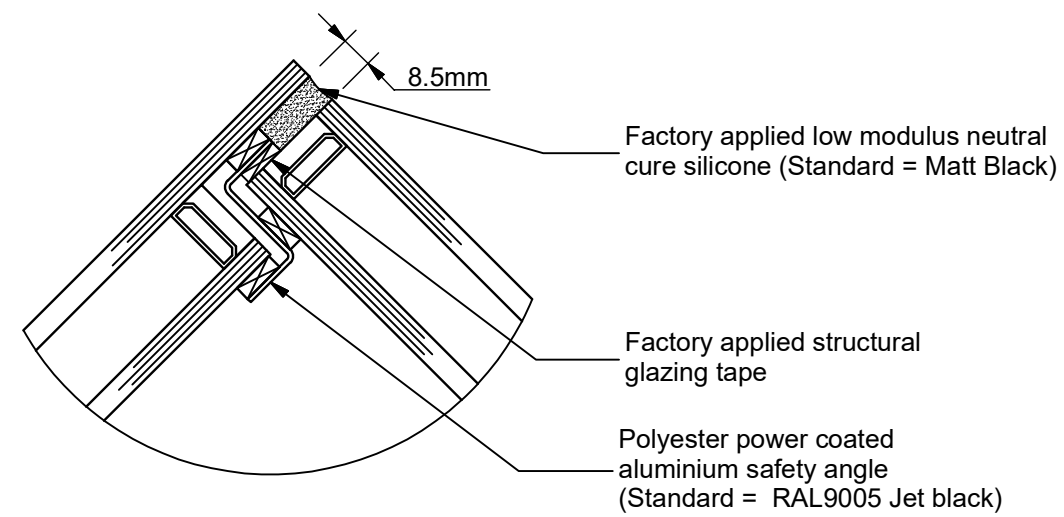

**Section C-C through corner join detail (Scale 1:2)**

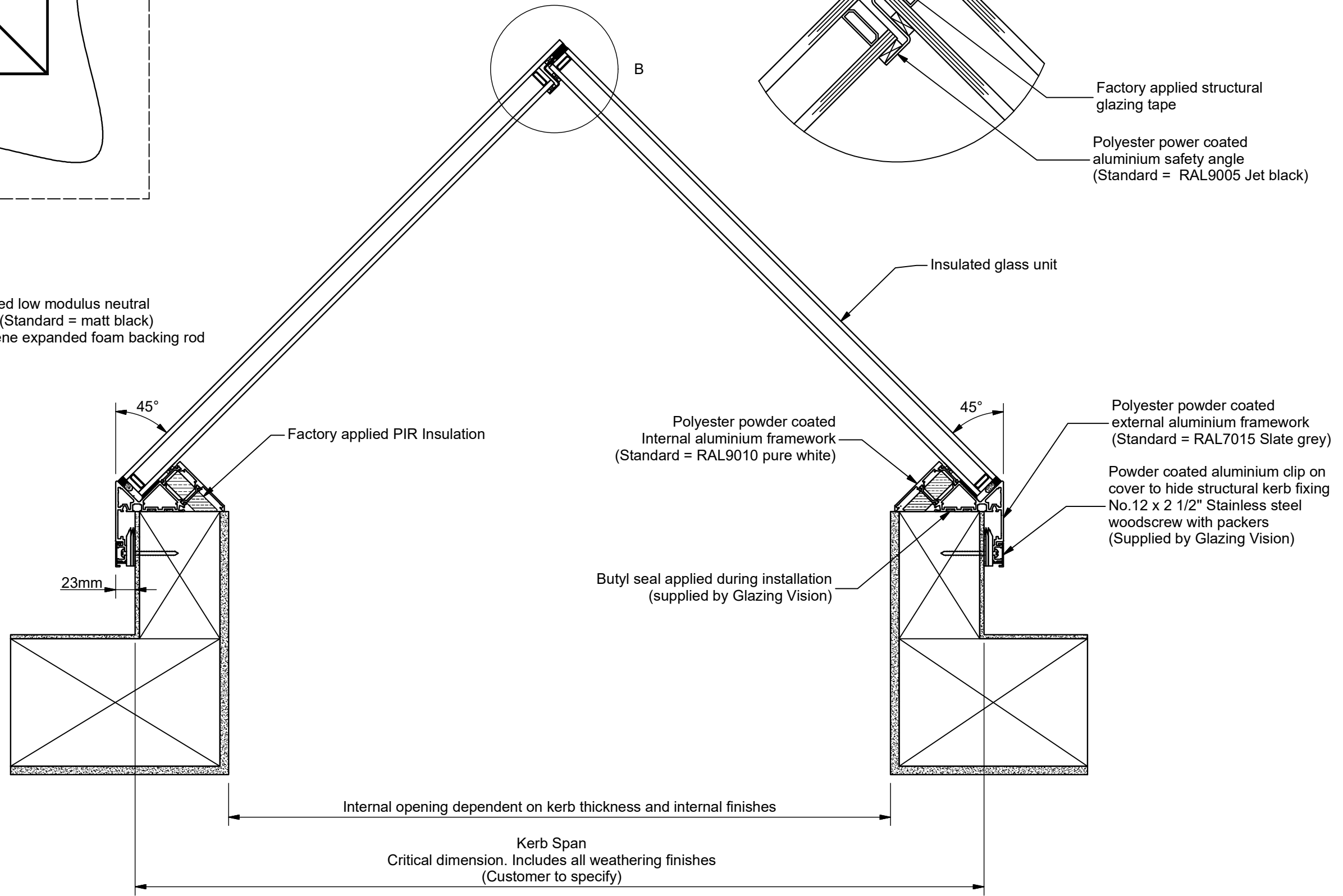
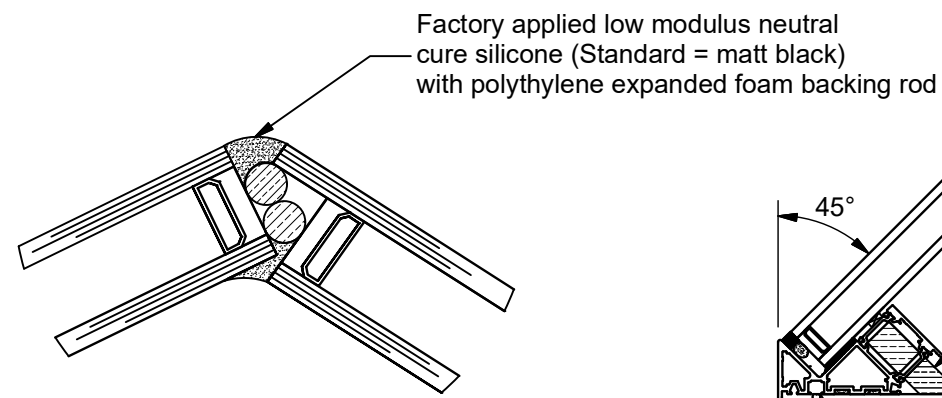

**GLAZING VISION**  
 Saw Mills Road  
 Diss  
 Norfolk  
 IP22 4RG  
 Tel: +44 (0)333 8000 881  
 Fax: +44 (0)333 8000 882  
 Email: sales@glazingvision.co.uk  
 Website: www.glazingvision.co.uk

IT IS GLAZING VISION'S POLICY TO CONTINUOUSLY DEVELOP AND IMPROVE OUR PRODUCTS. WE THEREFORE RESERVE THE RIGHT TO MODIFY OR CHANGE THE DETAIL DESIGN AT OUR DISCRETION AND WITHOUT PRIOR NOTICE. THIS DRAWING IS COPYRIGHT AND THE SOLE PROPERTY OF GLAZING VISION LTD. THE DESIGNS/INFORMATION IT CONTAINS ARE PRIVATE AND CONFIDENTIAL. IT MUST NOT BE COPIED, EXHIBITED OR COMMUNICATED TO THIRD PARTIES FOR ANY PURPOSE OTHER THAN THAT FOR WHICH IT WAS ISSUED WITHOUT THE WRITTEN PERMISSION OF GLAZING VISION LTD.

Third angle projection unless otherwise noted.  
 Tolerances:  
 Whole numbers = ±1mm  
 One decimal place = ±0.5mm  
 Two decimal places = ±0.2mm  
 All angles 90±0.5 degrees unless specified  
**IF IN DOUBT - ASK! DO NOT SCALE**  
**Supplier to deburr & remove sharp corners**

Rev	Revision Description	Drawn/Date
-	Initial release	JWL 10.03.14
B	(rev A Skipped ) Updated to change Stainless steel safety angle" to aluminium	HTT 19.11.19

<b>Product:</b> 404 - GV Standard Pyramid	<b>Checked By:</b> HL
<b>Description:</b> Section through elongated pyramid	
<b>Materials:</b> N/A	<b>Check Date:</b> 19.11.19
<b>Finish:</b> N/A	<b>Drawn By:</b> JWL
<b>Weight:</b> 742.851 kg	<b>Drawn Date:</b> 10.03.14
<b>Quantity:</b> N/A	<b>Drawing No:</b> 404-ASS-404
<b>Scale:</b> 1:25 1:5 1:2	