

Section C-C (Scale 1 : 10)

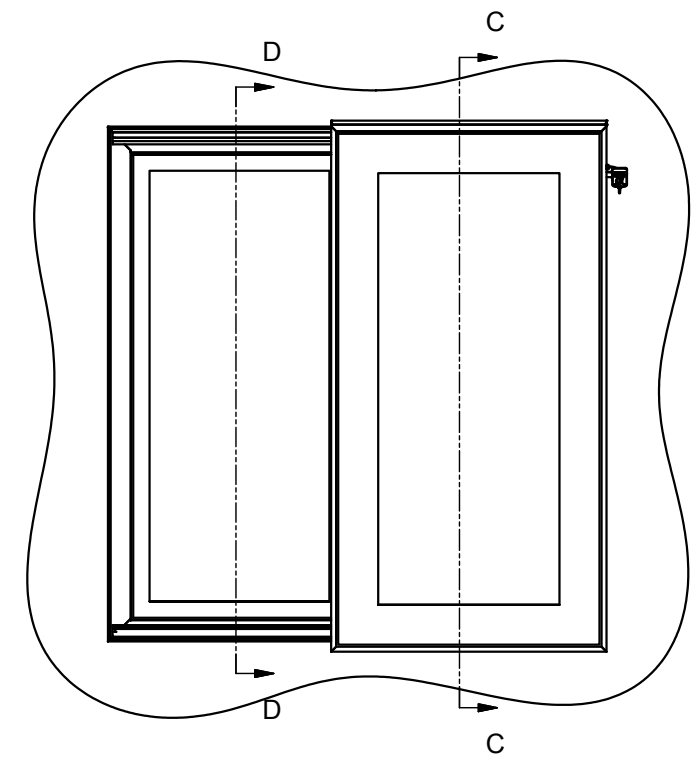

Detail E (Scale 1 : 2)

Section D-D (Scale 1 : 10)

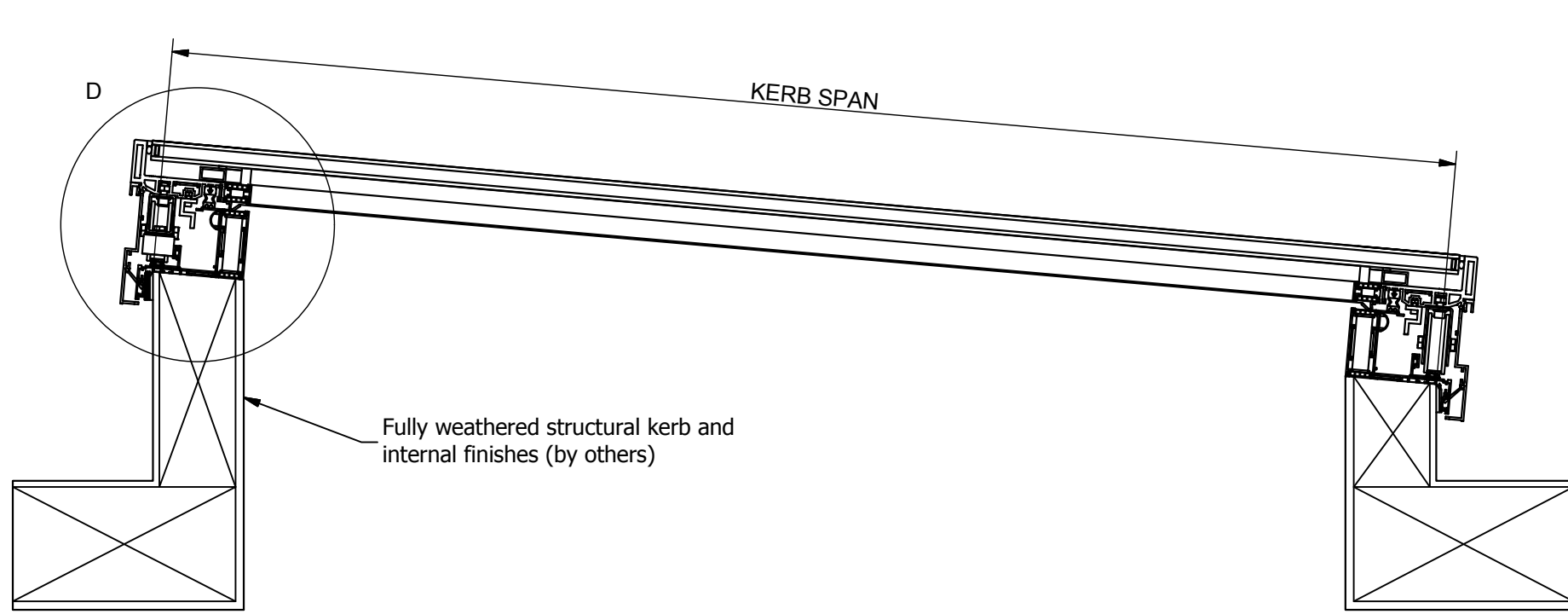
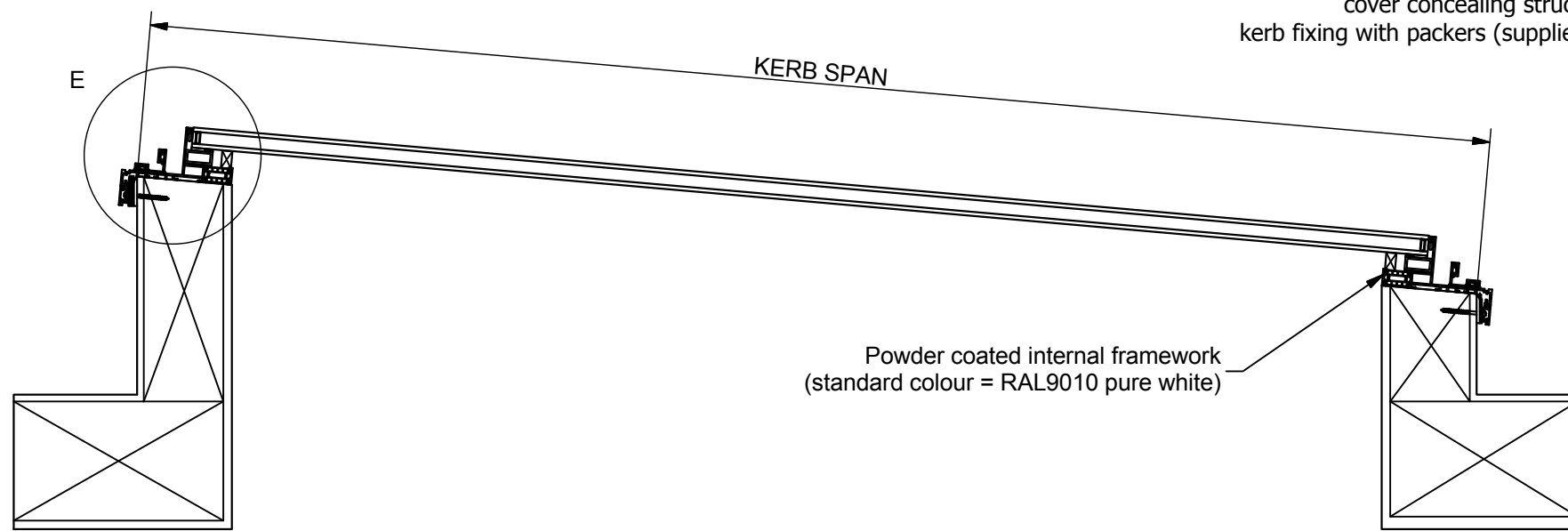

Factory applied low modulus neutral cure silicone (standard = matt black) with polyethylene expanded foam backing rod

Hard anodised track capping (natural anodised colour)

Polyester powder coated aluminium clip on cover concealing structural stainless steel kerb fixing with packers (supplied by Glazing Vision)

Fully weathered structural kerb and internal finishes (by others)

Powder coated internal framework (standard colour = RAL9010 pure white)

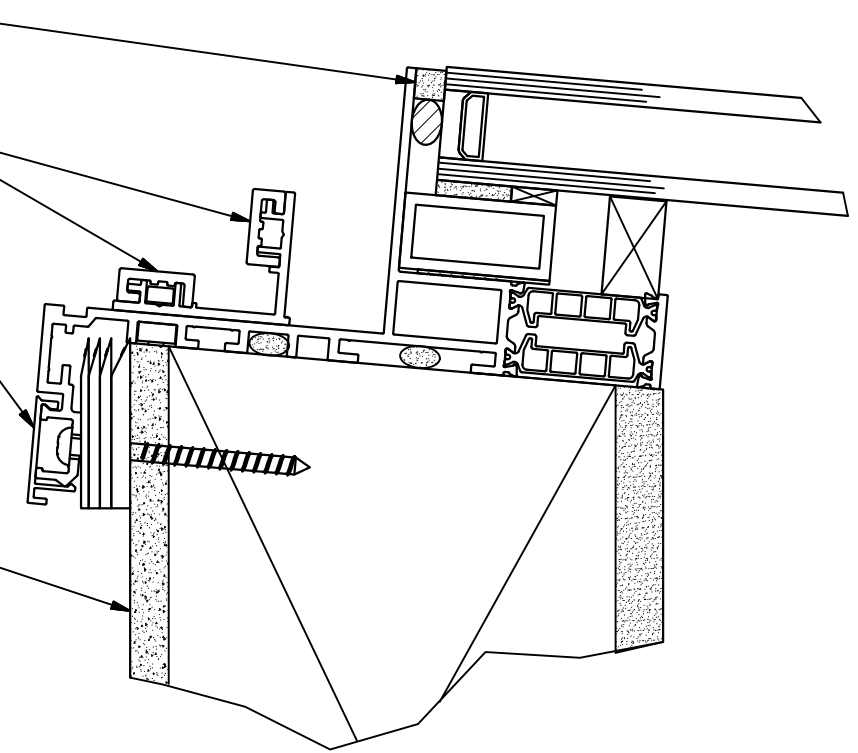

Rev	Revision Description	Drawn/Date
-	Initial release	PGW 13.03.2014

Product: 603 - GV Standard Sliding Over Fixed		Checked By: JamesB
Description: Sections through Span (double glaze)		Check Date: 13.03.2014
Materials: N/A	Drawn By: PGW	Quantity: N/A
Finish: Standard = RAL7015/RAL9010	Drawn Date: 13.03.2014	
Weight: N/A	Drawing No: 603-ASS-408	
Scale: 1:10		