

Detail B ( Scale 1 : 2 )

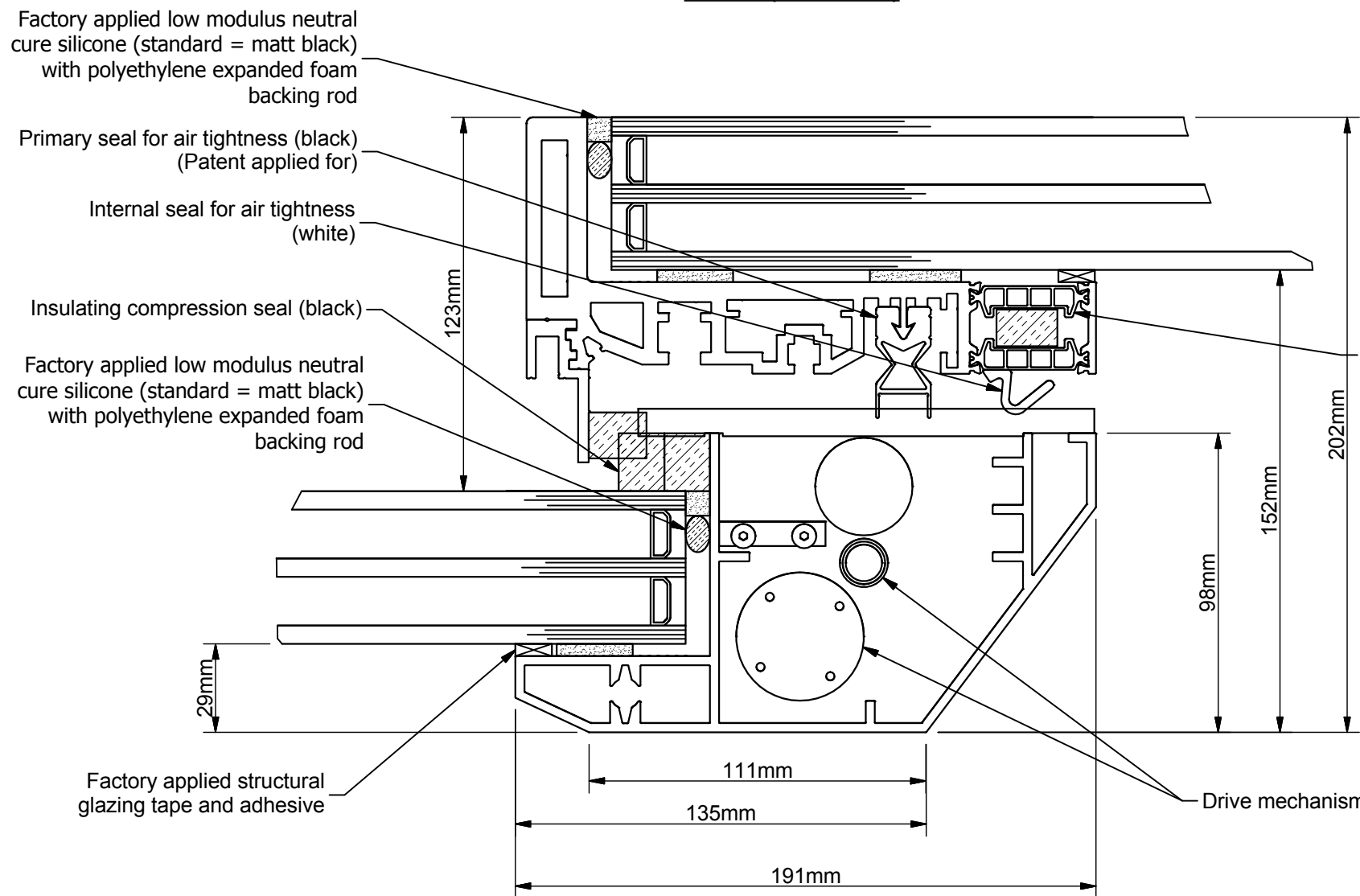

Detail C ( Scale 1 : 2 )

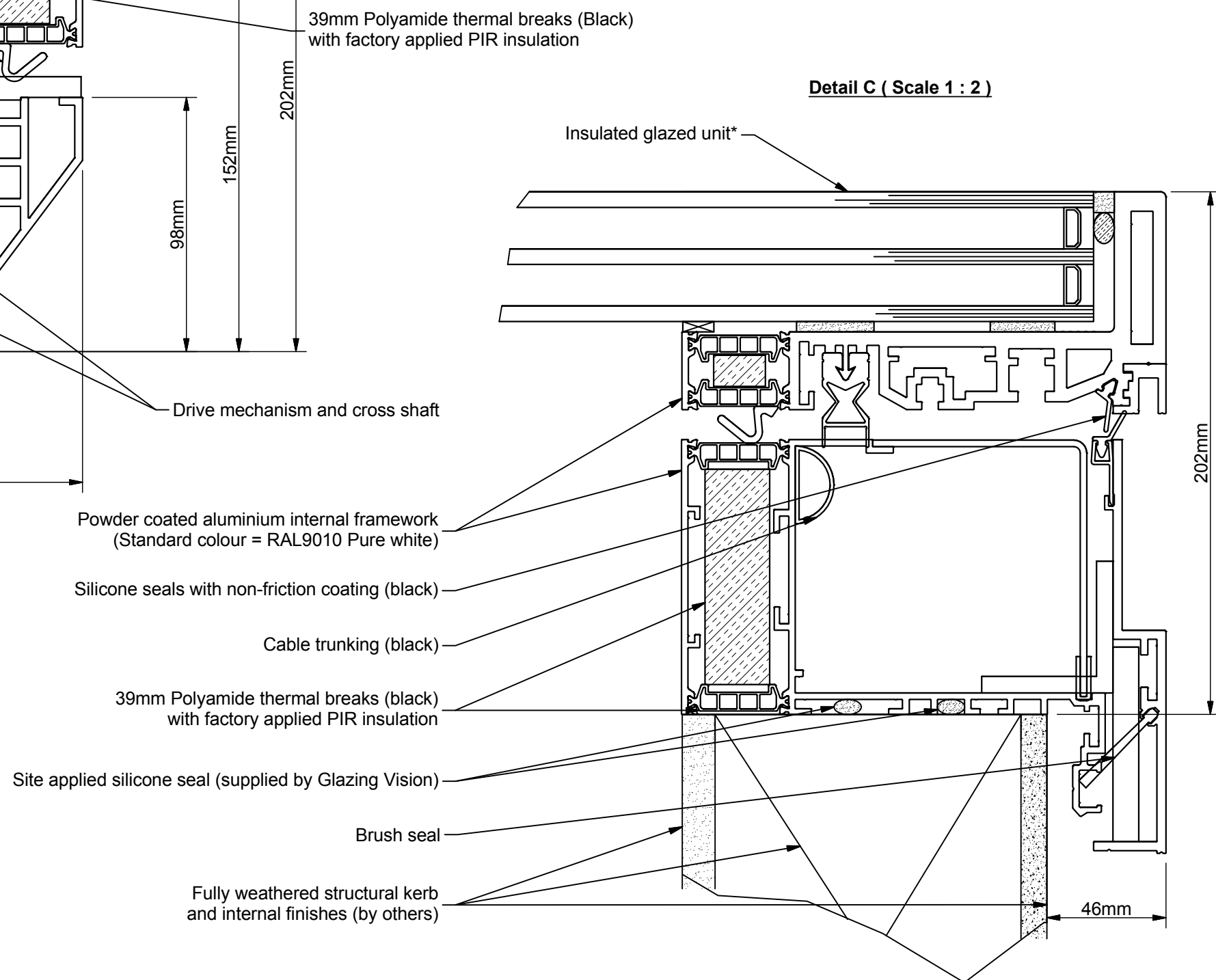

\*Glazed unit specification dependant on client options and glazing area

Refer to 603-ASS-406 for additional framework information

<p>Saw Mills Road Diss Norfolk IP22 4RG</p> <p>Tel: +44 (0)333 8000 881 Fax: +44 (0)333 8000 882 Email: sales@glazingvision.co.uk Website: www.glazingvision.co.uk</p>	<p>IT IS GLAZING VISION'S POLICY TO CONTINUOUSLY DEVELOP AND IMPROVE OUR PRODUCTS. WE THEREFORE RESERVE THE RIGHT TO MODIFY OR CHANGE THE DETAIL DESIGN AT OUR DISCRETION AND WITHOUT PRIOR NOTICE. THIS DRAWING IS COPYRIGHT AND THE SOLE PROPERTY OF GLAZING VISION LTD. THE DESIGNS/INFORMATION IT CONTAINS ARE PRIVATE AND CONFIDENTIAL. IT MUST NOT BE COPIED, EXHIBITED OR COMMUNICATED TO THIRD PARTIES FOR ANY PURPOSE OTHER THAN THAT FOR WHICH IT WAS ISSUED WITHOUT THE WRITTEN PERMISSION OF GLAZING VISION LTD.</p>	<p>Third angle projection unless otherwise noted. Tolerances: Whole numbers = ±1mm One decimal place = ±0.5mm Two decimal places = ±0.2mm All angles 90±0.5 degrees unless specified <b>IF IN DOUBT - ASK! DO NOT SCALE</b> Supplier to deburr &amp; remove sharp corners</p>	<p>Rev</p> <p>Initial release</p>	<p>Revision Description</p>	<p>Drawn/Date</p> <p>PGW 25.02.2014</p>	<p>Product: 603 - GV Standard Sliding Over Fixed</p> <p>Description: Detailed views B and C</p>	<p>Checked By:</p> <p>JamesB</p>
			<p>Materials: N/A</p> <p>Finish: Standard = RAL7015/RAL9010</p> <p>Weight: N/A</p> <p>Quantity: N/A</p> <p>Scale: 1:2</p>	<p>Drawn By: PGW</p> <p>Drawn Date: 25.02.2014</p> <p>Drawing No: 603-ASS-405</p>	<p>Check Date:</p> <p>25.02.2014</p>		