

Detail B (Scale 1 : 2)
Downlighter removed

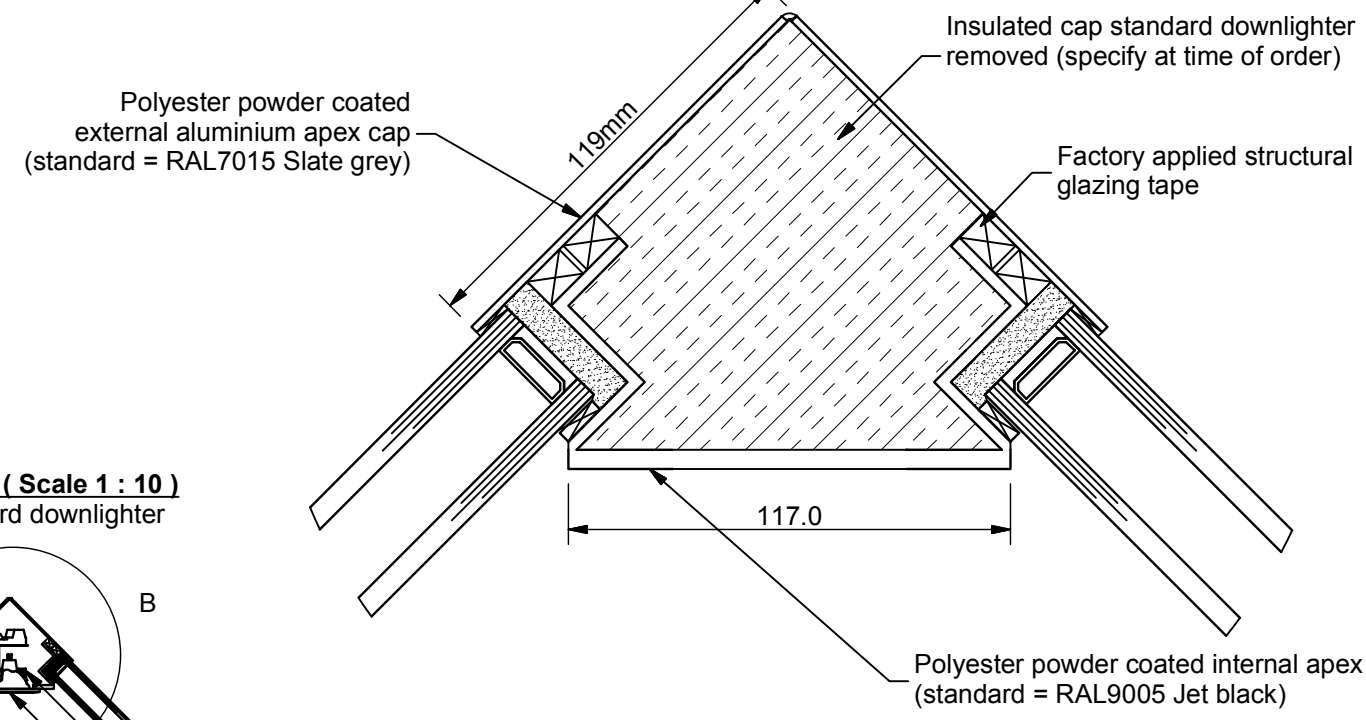

Section A-A (Scale 1 : 10)
With standard downlighter

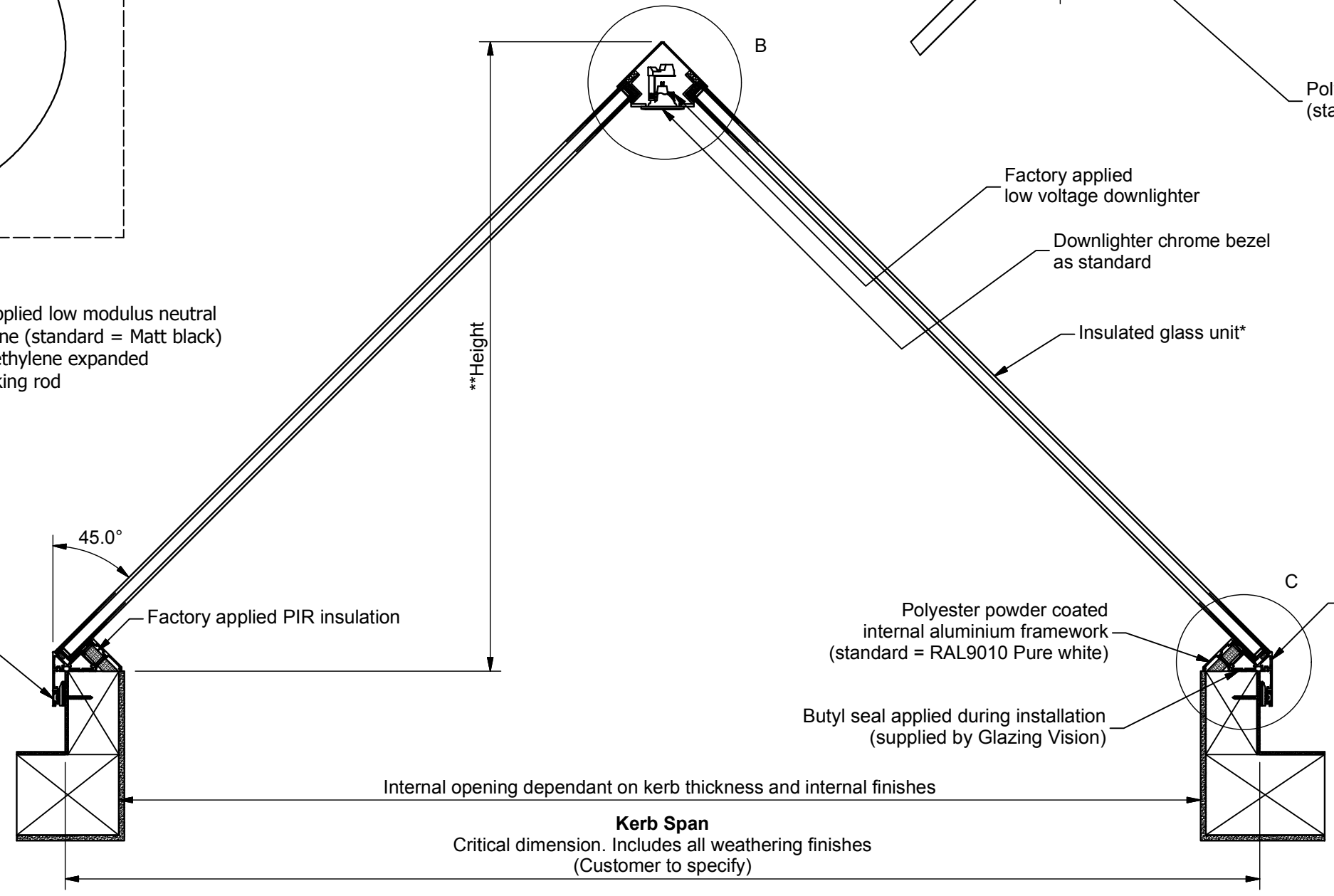

Section through glass corner join (Scale 1 : 2)

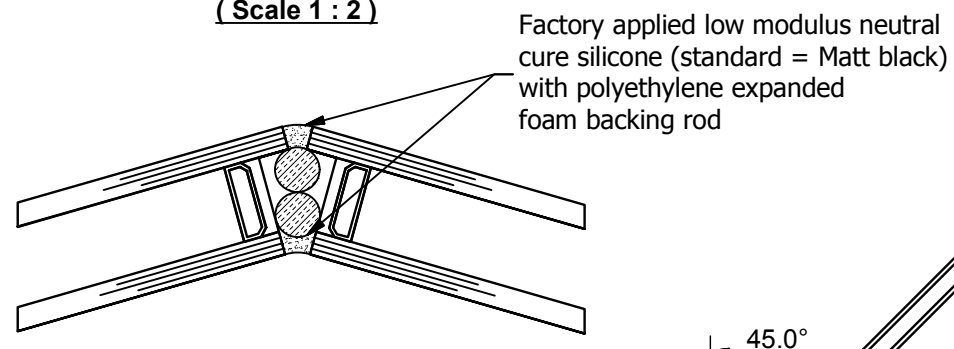

Powder coated aluminium clip on cover to hide structural kerb fixing No.12 x 2 1/2" Stainless steel wood screw with packers (supplied by Glazing Vision)

*Standard double glazed unit comprises:
6mm Clear HST toughened outer
20mm Warm edge argon filled silicone sealed spacer
6mm Clear HST soft coat low E toughened inner
Triple glazed option available

Detail C = 404-ASS-405
**Height ≈ (SPAN + 120mm)/2

GLAZING VISION
Saw Mills Road
Diss
Norfolk
IP22 4RG
Tel: +44 (0)333 8000 881
Fax: +44 (0)333 8000 882
Email: sales@glazingvision.co.uk
Website: www.glazingvision.co.uk

IT IS GLAZING VISION'S POLICY TO CONTINUOUSLY DEVELOP AND IMPROVE OUR PRODUCTS. WE THEREFORE RESERVE THE RIGHT TO MODIFY OR CHANGE THE DETAIL DESIGN AT OUR DISCRETION AND WITHOUT PRIOR NOTICE. THIS DRAWING IS COPYRIGHT AND THE SOLE PROPERTY OF GLAZING VISION LTD. THE DESIGNS/INFORMATION IT CONTAINS ARE PRIVATE AND CONFIDENTIAL. IT MUST NOT BE COPIED, EXHIBITED OR COMMUNICATED TO THIRD PARTIES FOR ANY PURPOSE OTHER THAN THAT FOR WHICH IT WAS ISSUED WITHOUT THE WRITTEN PERMISSION OF GLAZING VISION LTD.

Third angle projection unless otherwise noted.
Tolerances:
Whole numbers = ±1mm
One decimal place = ±0.5mm
Two decimal places = ±0.2mm
All angles 90±0.5 degrees unless specified
IF IN DOUBT - ASK! DO NOT SCALE
Supplier to deburr & remove sharp corners

Rev	Revision Description	Drawn/Date
-	Initial release	JWL 14.03.14

Product: 404 - GV Standard Octagonal Pyramid	Checked By: PGW
Description: Section through octagonal pyramid	Check Date: 14.03.14
Materials: N/A	Drawn By: JWL
Finish: N/A	Drawn Date: 14.03.14
Weight: N/A	Quantity: N/A
Scale: 1:25 1:10 1:2	Drawing No: 404-ASS-411