

Section B-B (Scale 1 : 2)

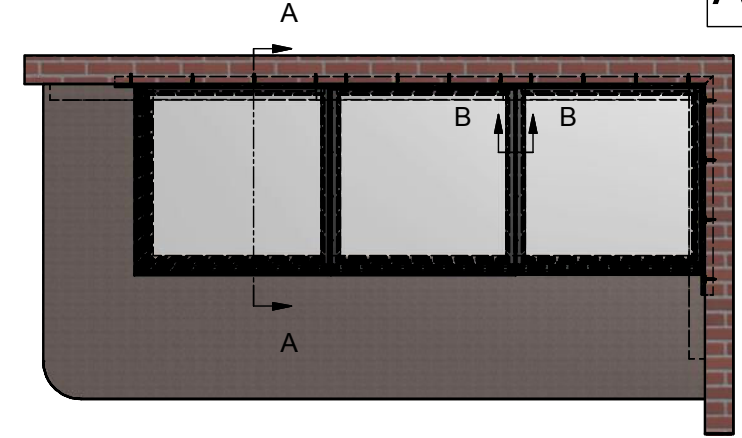

Note: This is a standard reference drawing which includes both wall and kerb mounting details to illustrate the possible configurations for the flushglaze range. It is not an order specific drawing and therefore does not reflect your specific order dimensions or configuration. Ensure you check your order confirmation meets the specifics of your order before signing.

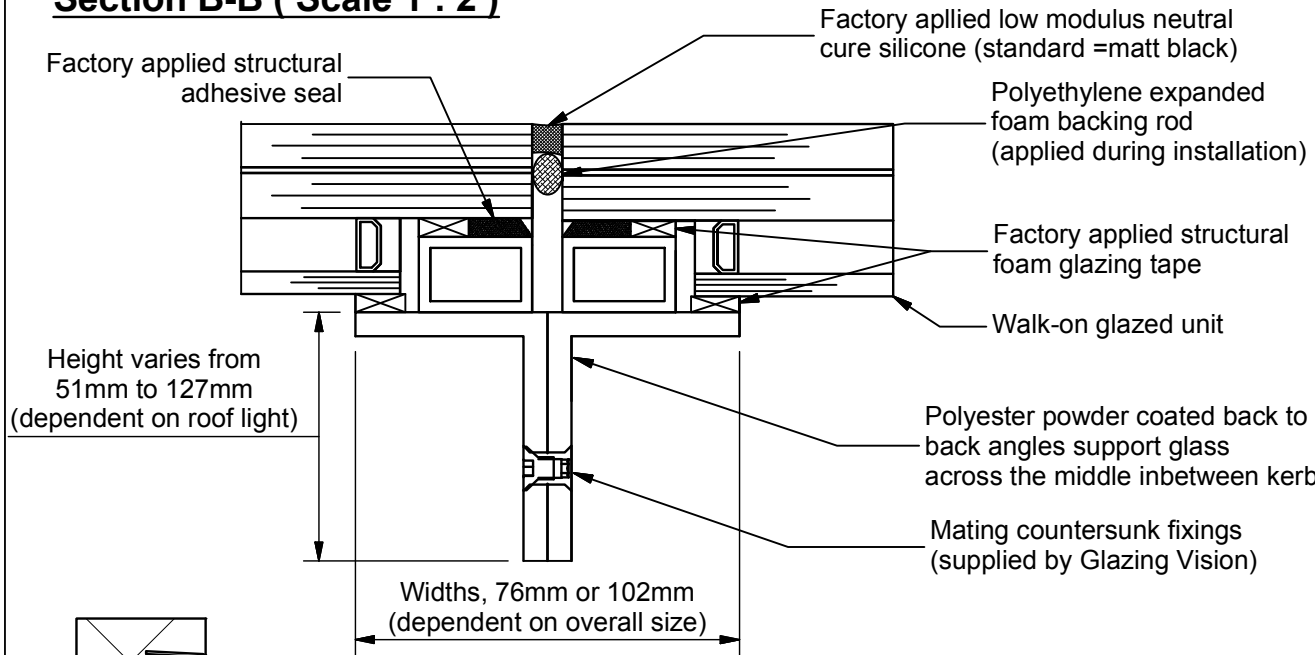
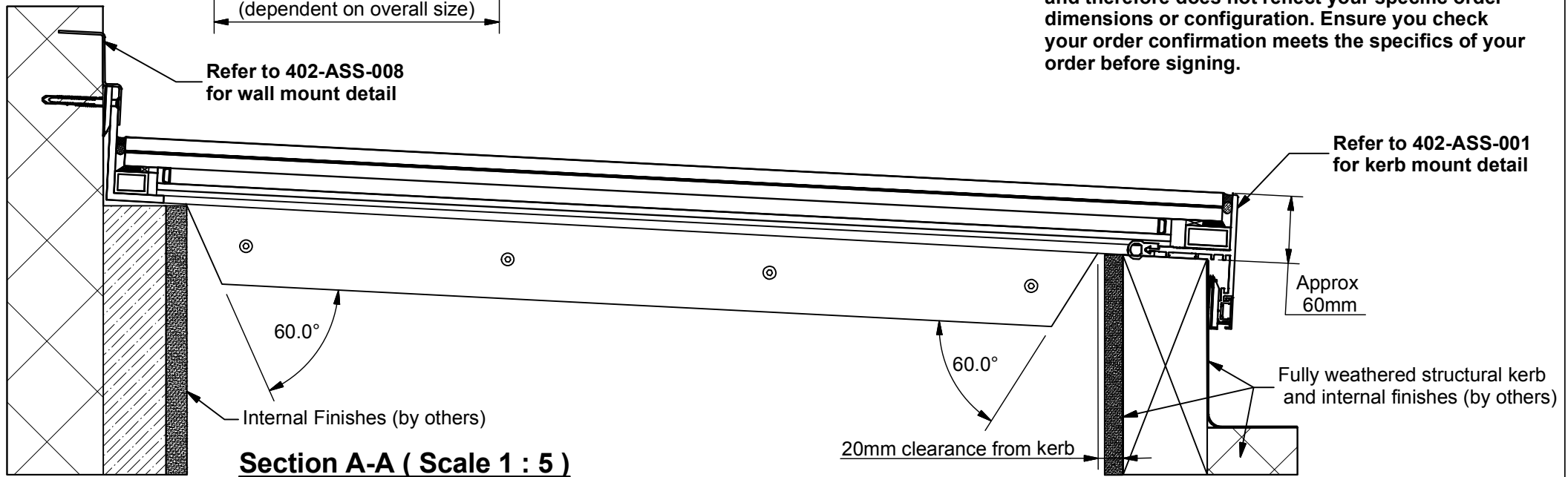

Saw Mills Road
Diss
Norfolk
IP22 4RG
Tel: +44 (0)333 8000 881
Fax: +44 (0)333 8000 882
Email: sales@glazingvision.co.uk
Website: www.glazingvision.co.uk

IT IS GLAZING VISION'S POLICY TO CONTINUOUSLY DEVELOP AND IMPROVE OUR PRODUCTS. WE THEREFORE RESERVE THE RIGHT TO MODIFY OR CHANGE THE DETAIL DESIGN AT OUR DISCRETION AND WITHOUT PRIOR NOTICE. THIS DRAWING IS COPYRIGHT AND THE SOLE PROPERTY OF GLAZING VISION LTD. THE DESIGNS/INFORMATION IT CONTAINS ARE PRIVATE AND CONFIDENTIAL. IT MUST NOT BE COPIED, EXHIBITED OR COMMUNICATED TO THIRD PARTIES FOR ANY PURPOSE OTHER THAN THAT FOR WHICH IT WAS ISSUED WITHOUT THE WRITTEN PERMISSION OF GLAZING VISION LTD.

Third angle projection unless otherwise noted.
Tolerances:
Whole numbers = ±1mm
One decimal place = ±0.5mm
Two decimal places = ±0.2mm
All angles 90±0.5 degrees unless specified
IF IN DOUBT - ASK! DO NOT SCALE
Supplier to deburr & remove sharp corners

Rev	Revision Description	Drawn/Date
P	Description changed to suit data sheet	SW 11.04.16
O	Dims added	SW 09.10.15

Product: 402-Flushglaze		Checked By: JWL
Description: Walk-on Flushglaze multipart		
Materials: N/A	Drawn By: SW	Check Date: 11.04.2016
Finish: N/A	Drawn Date: 16.07.2015	
Weight: N/A		
Quantity: N/A		
Scale: 1:5, 1:2 & 1:40 @ A4		Drawing No: 402-ASS-016