

Section A-A (Scale 1 : 10)

(Across the fall)

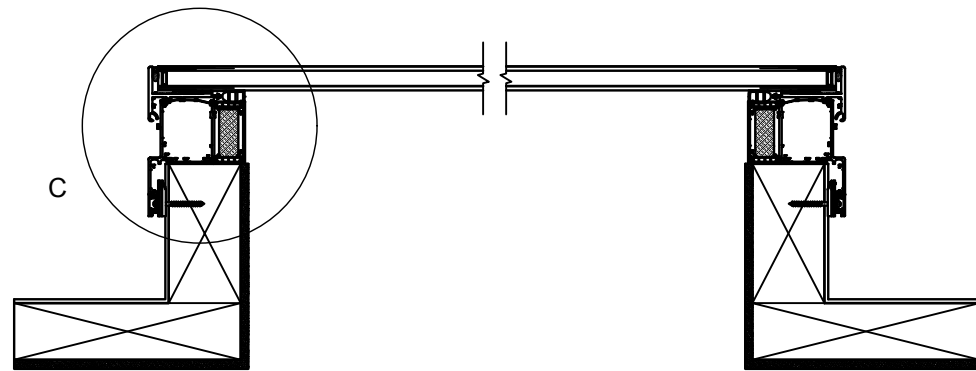

Detail C (Scale 1:2)

Through opening end

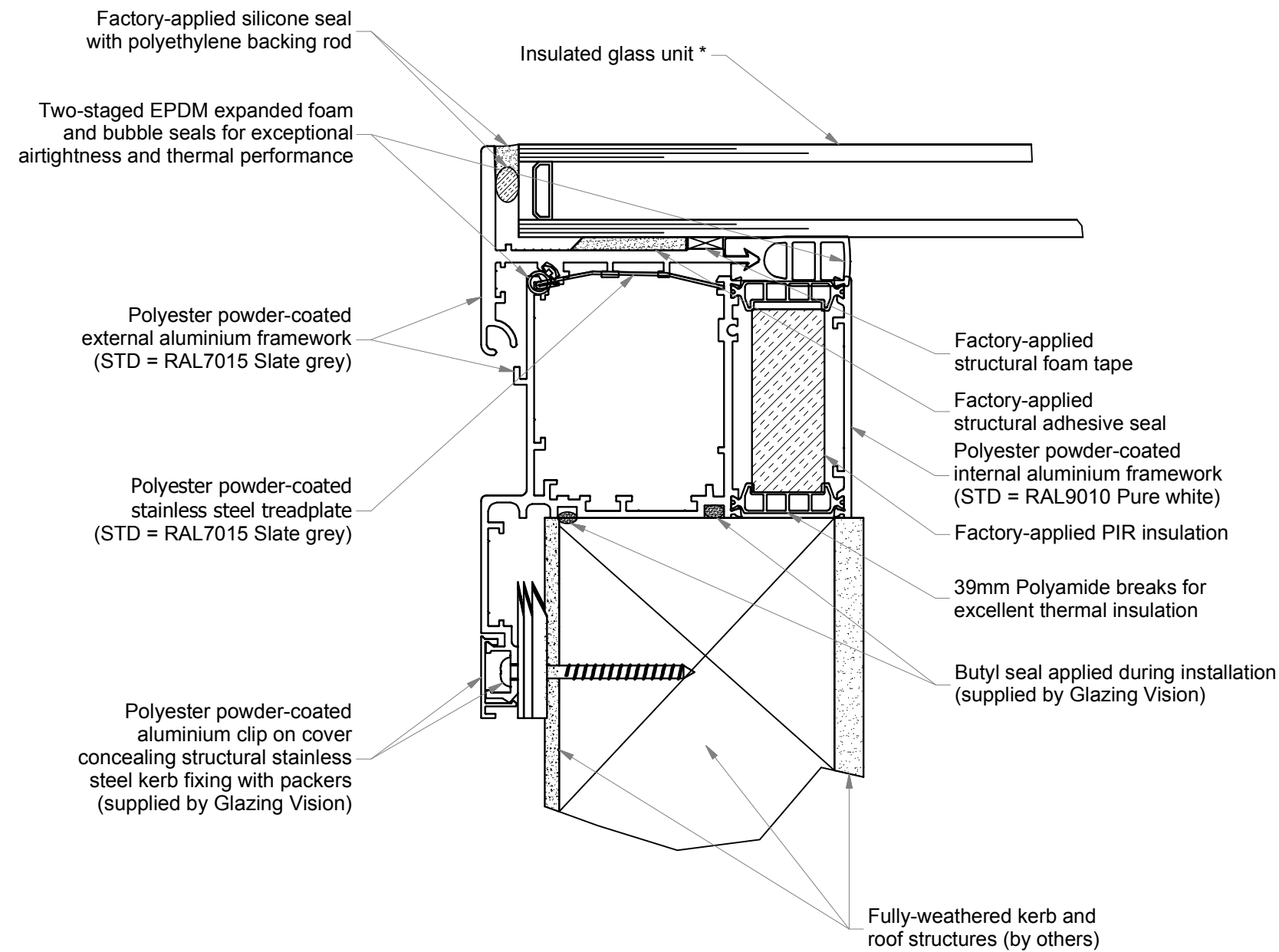

*Standard double glazed unit comprises:
 6mm Clear HST toughened outer
 20mm Warm edge argon filled silicone sealed spacer
 6mm Clear HST toughened soft coat low E inner

Standard colour:
 RAL7015 Slate Grey outer
 RAL9010 Pure White inner

<p>Saw Mills Road Diss Norfolk IP22 4RG</p> <p>Tel: +44 (0)333 8000 881 Fax: +44 (0)333 8000 882 Email: sales@glazingvision.co.uk Website: www.glazingvision.co.uk</p>	<p>IT IS GLAZING VISION'S POLICY TO CONTINUOUSLY DEVELOP AND IMPROVE OUR PRODUCTS. WE THEREFORE RESERVE THE RIGHT TO MODIFY OR CHANGE THE DETAIL DESIGN AT OUR DISCRETION AND WITHOUT PRIOR NOTICE. THIS DRAWING IS COPYRIGHT AND THE SOLE PROPERTY OF GLAZING VISION LTD. THE DESIGNS/INFORMATION IT CONTAINS ARE PRIVATE AND CONFIDENTIAL. IT MUST NOT BE COPIED, EXHIBITED OR COMMUNICATED TO THIRD PARTIES FOR ANY PURPOSE OTHER THAN THAT FOR WHICH IT WAS ISSUED WITHOUT THE WRITTEN PERMISSION OF GLAZING VISION LTD.</p>	<p>Third angle projection unless otherwise noted. Tolerances: Whole numbers = ±1mm One decimal place = ±0.5mm Two decimal places = ±0.2mm All angles 90±0.5 degrees unless specified IF IN DOUBT - ASK! DO NOT SCALE Supplier to deburr & remove sharp corners</p>	<p>Rev</p>	<p>Revision Description</p>	<p>Drawn/ Date</p>	<p>Product: 407 - GV Standard Skyhatch Electric Description: Section A-A</p>	<p>Checked By: GH</p>	
			<p>-</p>	<p>Initial release</p>	<p>JWL 08.10.15</p>	<p>Materials: N/A Finish: N/A Weight: N/A Quantity: N/A Scale: 1:10 1:2</p>	<p>Drawn By: JWL Drawn Date: 08.10.15</p>	<p>Check Date: 08.10.15</p>
							<p>Drawing No: 407-ASS-005</p>	