

**GV STANDARD X-VENT**  
ELECTRONICALLY OPERATED AOV HINGED ROOFLIGHT

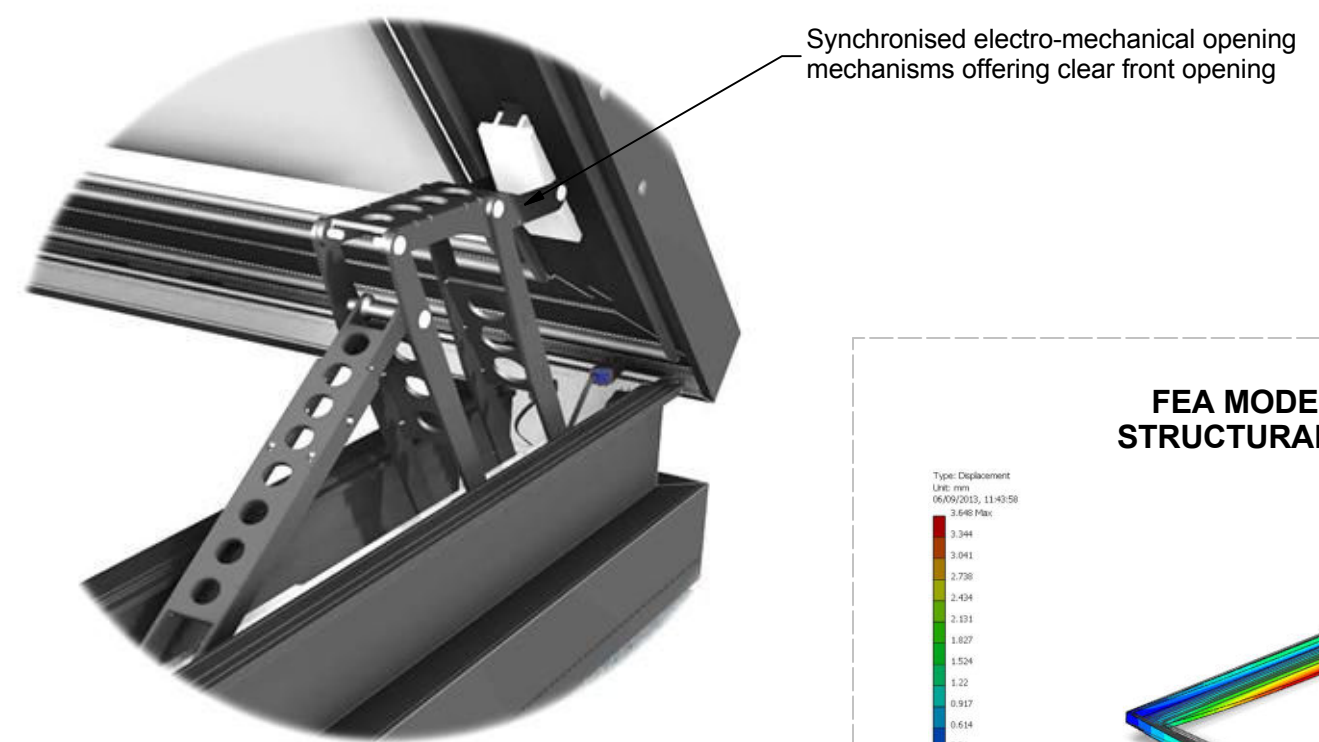

**FEA MODELLED FOR STRUCTURAL INTEGRITY**

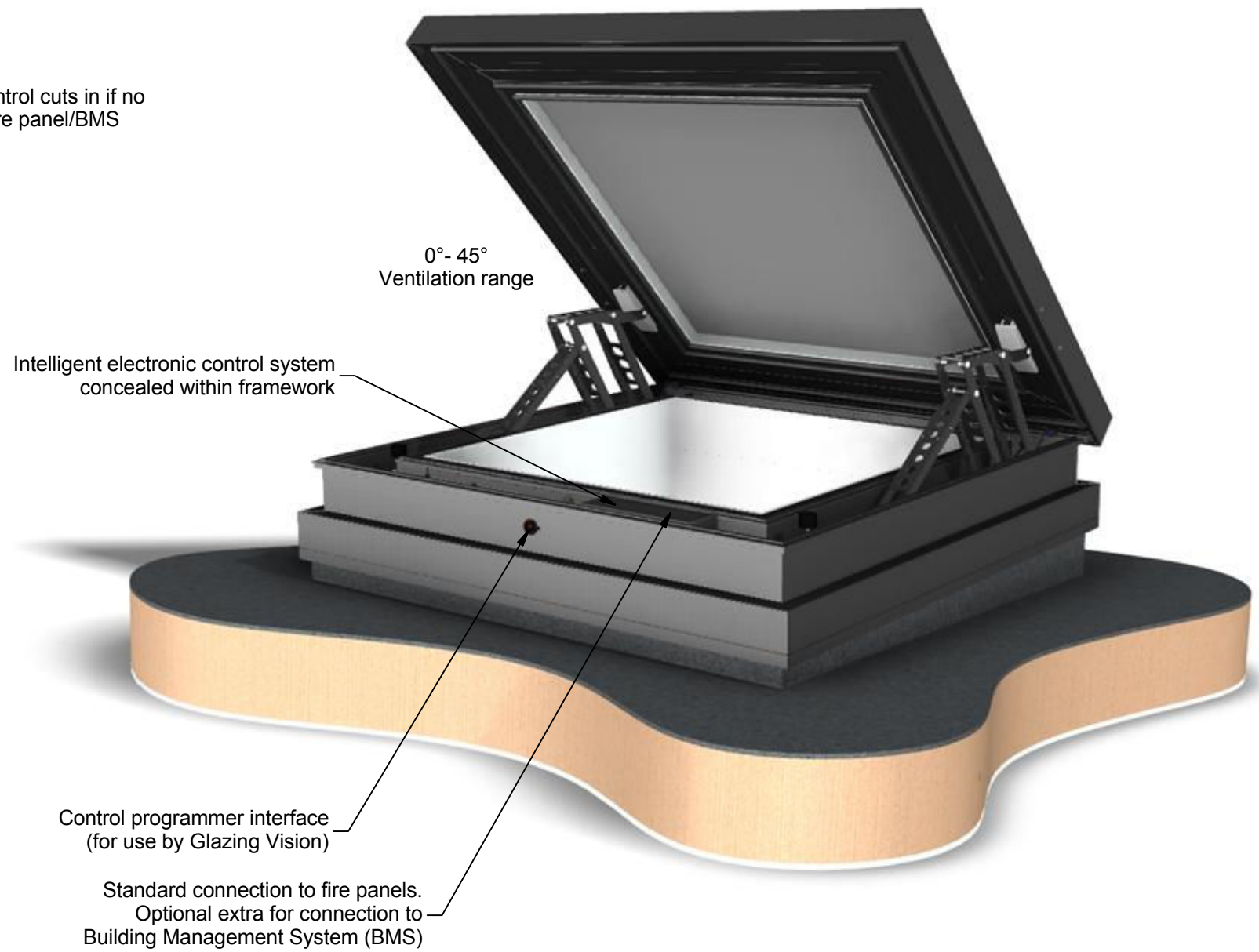
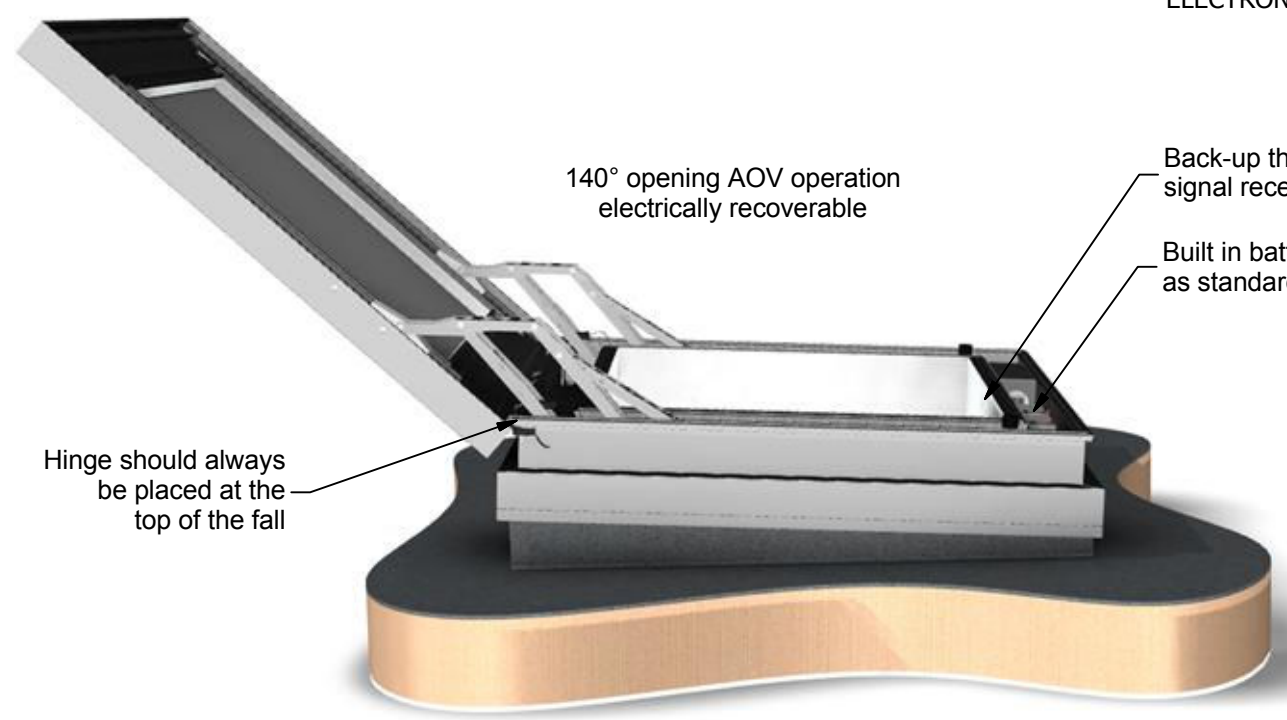
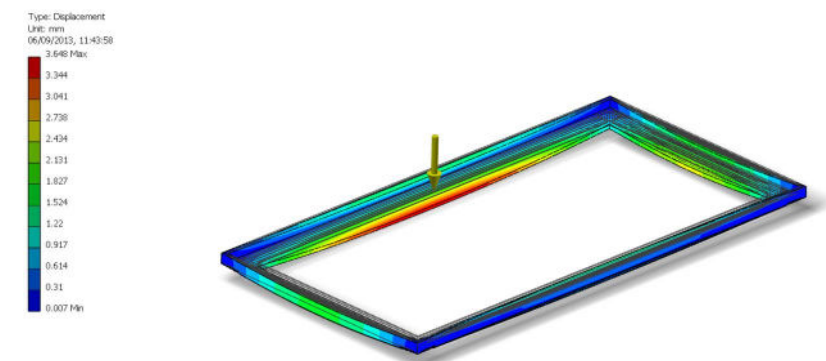

**THERMALLY MODELLED FOR INDUSTRY LEADING EFFICIENCY**

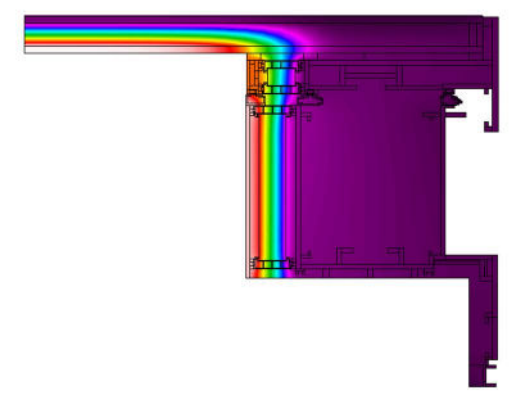

**REQUIRES WEATHERED KERB (NOT SUPPLIED)**  
**REFER TO DRAWINGS:**  
405-ASS-402  
405-ASS-403  
405-ASS-404  
405-ASS-405  
**FOR DETAILS**

**GLAZING VISION**  
Saw Mills Road  
Diss  
Norfolk  
IP22 4RG  
Tel: +44 (0)333 8000 881  
Fax: +44 (0)333 8000 882  
Email: sales@glazingvision.co.uk  
Website: www.glazingvision.co.uk

IT IS GLAZING VISION'S POLICY TO CONTINUOUSLY DEVELOP AND IMPROVE OUR PRODUCTS. WE THEREFORE RESERVE THE RIGHT TO MODIFY OR CHANGE THE DETAIL DESIGN AT OUR DISCRETION AND WITHOUT PRIOR NOTICE. THIS DRAWING IS COPYRIGHT AND THE SOLE PROPERTY OF GLAZING VISION LTD. THE DESIGNS/INFORMATION IT CONTAINS ARE PRIVATE AND CONFIDENTIAL. IT MUST NOT BE COPIED, EXHIBITED OR COMMUNICATED TO THIRD PARTIES FOR ANY PURPOSE OTHER THAN THAT FOR WHICH IT WAS ISSUED WITHOUT THE WRITTEN PERMISSION OF GLAZING VISION LTD.

Third angle projection unless otherwise noted.  
Tolerances:  
Whole numbers = ±1mm  
One decimal place = ±0.5mm  
Two decimal places = ±0.2mm  
All angles 90±0.5 degrees unless specified  
**IF IN DOUBT - ASK! DO NOT SCALE**  
**Supplier to deburr & remove sharp corners**

Rev	Revision Description	Drawn/Date
-	Initial release	JWL 12.02.14

<b>Product:</b> 405 - GV Standard X-Vent		<b>Checked By:</b> PGW
<b>Description:</b> Product overview		
<b>Materials:</b> N/A	<b>Drawn By:</b> JWL	<b>Check Date:</b> 12.02.14
<b>Finish:</b> N/A	<b>Drawn Date:</b> 12.02.14	
<b>Weight:</b> N/A	<b>Quantity:</b> N/A	<b>Drawing No:</b> 405-ASS-401
<b>Scale:</b> NTS		