

Product Height	
Glass Spec	Product Height
25.5 mm	35.0 mm
33.0 mm	44.5 mm
39.0 mm	51.0 mm

Section (Scale 1 : 4)

Section through installation detail

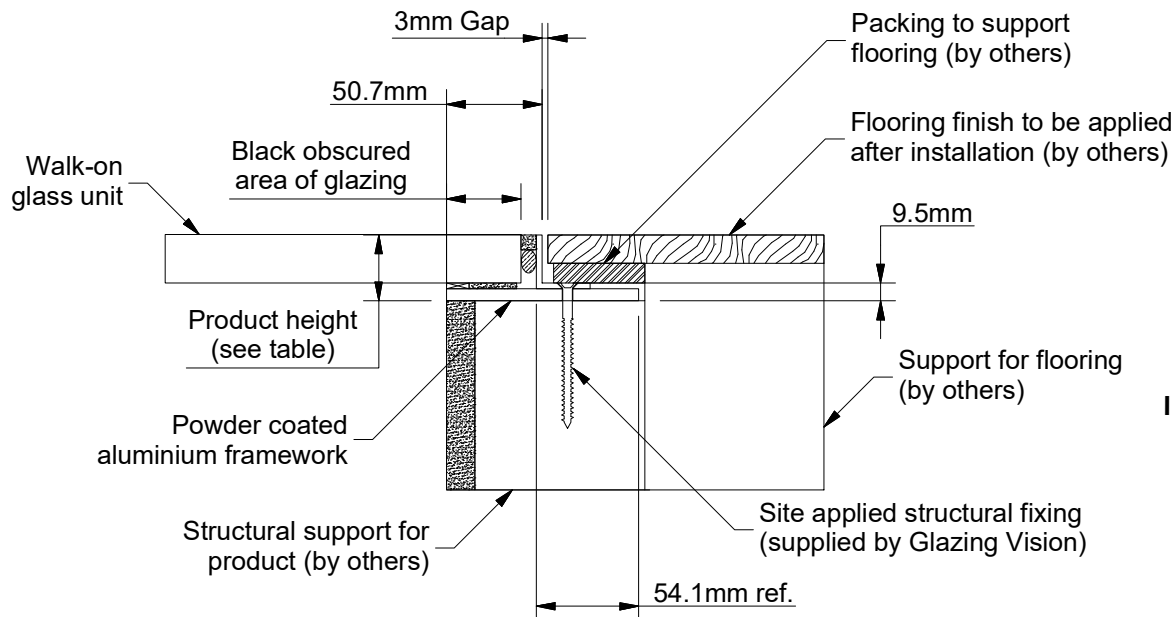

Section (Scale 1 : 4)

Upstand dimensions to be constructed by others

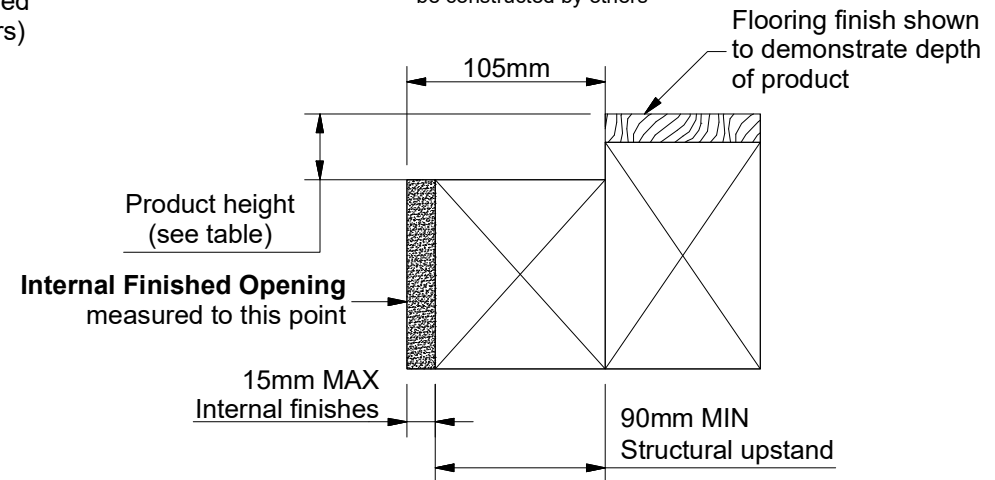

GLAZING VISION

Saw Mills Road
Diss
Norfolk
IP22 4RG

Tel: +44 (0)333 8000 881
Fax: +44 (0)333 8000 882
Email: sales@glazing-vision.co.uk
Website: www.glazing-vision.co.uk

IT IS GLAZING VISION'S POLICY TO CONTINUOUSLY DEVELOP AND IMPROVE OUR PRODUCTS. AND THEREFORE RESERVE THE RIGHT TO MODIFY OR CHANGE THE DETAIL DESIGN AT OUR DISCRETION AND WITHOUT PRIOR NOTICE. THIS DRAWING IS COPYRIGHT AND THE SOLE PROPERTY OF GLAZING VISION LTD. THE DESIGNS/INFORMATION IT CONTAINS ARE PRIVATE AND CONFIDENTIAL. IT MUST NOT BE COPIED, EXHIBITED OR COMMUNICATED TO THIRD PARTIES FOR ANY PURPOSE OTHER THAN THAT FOR WHICH IT WAS ISSUED WITHOUT THEIR WRITTEN PERMISSION.

Third angle projection unless otherwise noted.
Tolerances:
Whole numbers = ±1mm
One decimal place = ±0.5mm
Two decimal places = ±0.2mm
Angular = ±0.5 degree
IF IN DOUBT - ASK! DO NOT SCALE
Supplier to deburr & remove sharp corners

Rev	Revision Description	Drawn/Date
D	Kerb section view clarified	JSL 28.03.18
E	Updated for redesign for bigger range of glass thicknesses	HL 28.11.19

Product: GV Standard Internal Walk-On		Checked By: JSL
Description: Internal Walk-On		
Materials: N/A	Drawn By: JamesB	Check Date: 28.11.19
Finish: N/A	Drawn Date: 19.04.12	
Weight: N/A	Drawing No: 402-ASS-050	
Quantity: N/A		
Scale: N/A		