

GV Standard PitchVent - Manual Crank

Manually opened hinged pitched roofwindow
Double glazed only

Hinge should always be at the top of the fall

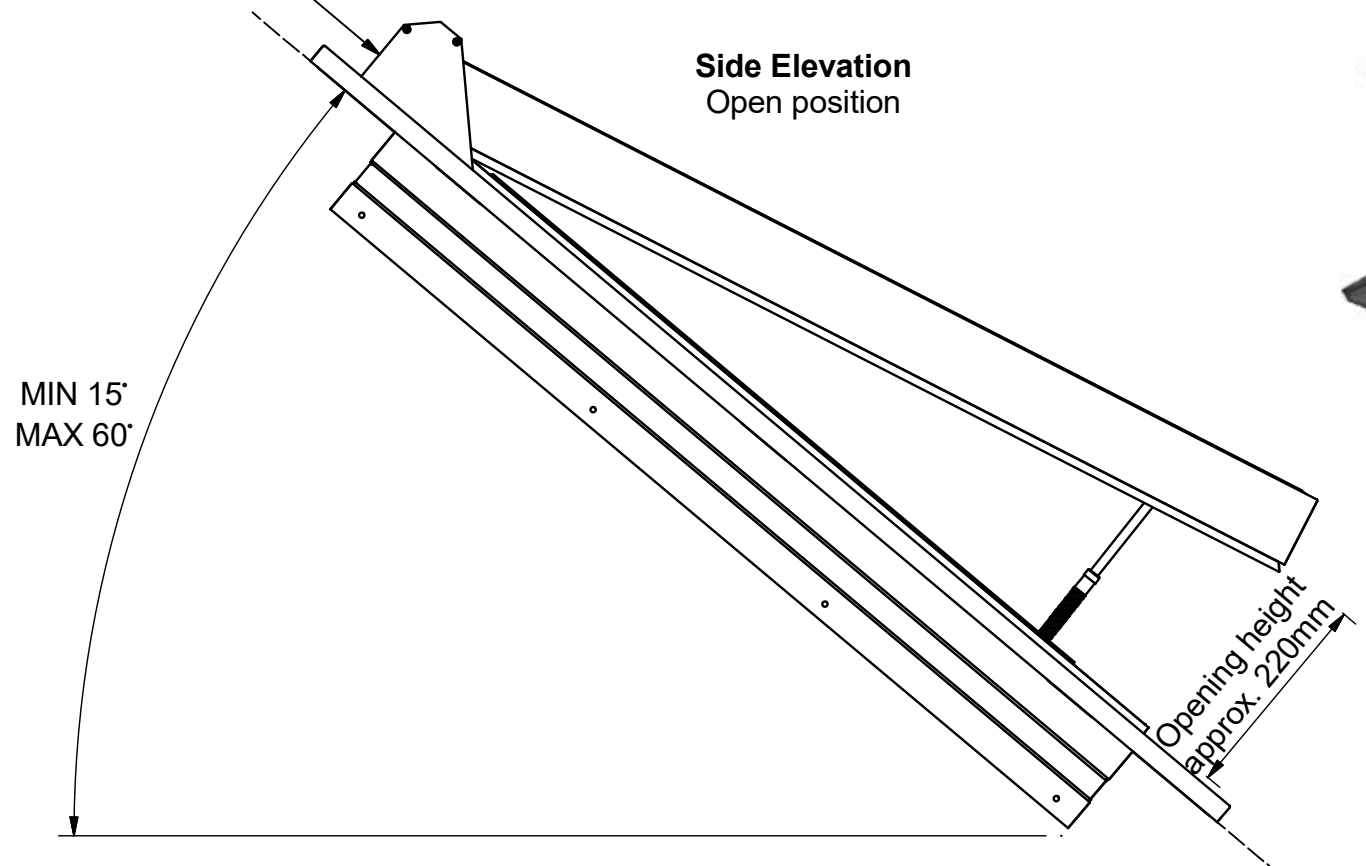

Mechanism Detail

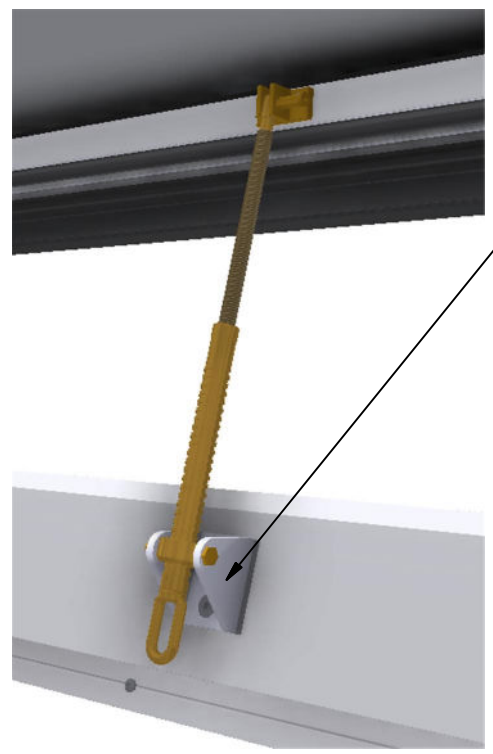

Site applied telescopic spindle brass finish as standard. To avoid mechanism clashing, internal finishes must not protrude beyond framework.

FEA MODELLED FOR STRUCTURAL INTEGRITY

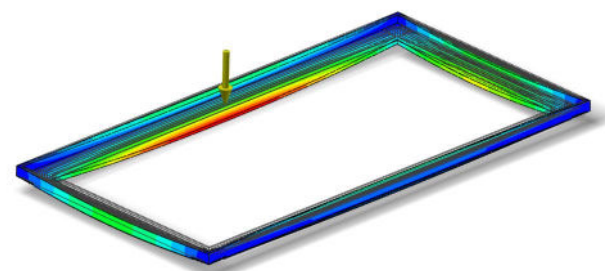
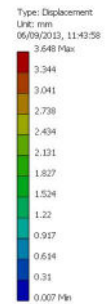

THERMALLY-MODELLED FOR INDUSTRY LEADING EFFICIENCY

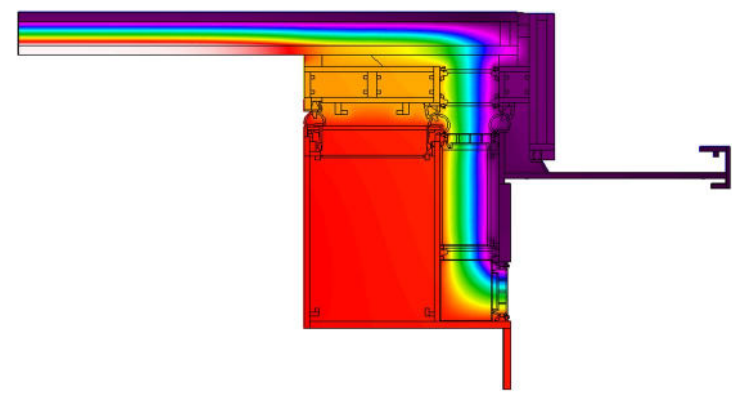

FOR DIMENSIONING AND INSTALLATION INFORMATION REFER TO DRAWINGS:

- 202-ASS-001
- 202-ASS-002
- 202-ASS-003
- 202-ASS-004
- 202-ASS-005

GLAZING VISION
Saw Mills Road
Diss
Norfolk
IP22 4RG
Tel: +44 (0)333 8000 881
Fax: +44 (0)333 8000 882
Email: sales@glazingvision.co.uk
Website: www.glazingvision.co.uk

IT IS GLAZING VISION'S POLICY TO CONTINUOUSLY DEVELOP AND IMPROVE OUR PRODUCTS. WE THEREFORE RESERVE THE RIGHT TO MODIFY OR CHANGE THE DETAIL DESIGN AT OUR DISCRETION AND WITHOUT PRIOR NOTICE. THIS DRAWING IS COPYRIGHT AND THE SOLE PROPERTY OF GLAZING VISION LTD. THE DESIGNS/INFORMATION IT CONTAINS ARE PRIVATE AND CONFIDENTIAL. IT MUST NOT BE COPIED, EXHIBITED OR COMMUNICATED TO THIRD PARTIES FOR ANY PURPOSE OTHER THAN THAT FOR WHICH IT WAS ISSUED WITHOUT THE WRITTEN PERMISSION OF GLAZING VISION LTD.

Third angle projection unless otherwise noted.
Tolerances:
Whole numbers = ±1mm
One decimal place = ±0.5mm
Two decimal places = ±0.2mm
All angles 90±0.5 degrees unless specified
IF IN DOUBT - ASK! DO NOT SCALE
Supplier to deburr & remove sharp corners

Rev	Revision Description	Drawn/Date
-	Initial Release	HL 02.02.18

Product: 202 - PitchVent		Checked By: JSL
Description: Manual Crank PitchVent General Arrangement Details		
Materials: N/A	Drawn By: HL	Check Date: 02.02.18
Finish: N/A	Drawn Date: 02.02.18	
Weight: N/A	Drawing No: 202-ASS-007	
Quantity: N/A		
Scale: N/A		

Checked By:
JSL
Check Date:
02.02.18