

**GV Standard Pitchglaze MkII
Small Frame**

Used for glass between 26mm & 34.8mm in thickness
(typically double glazed units)

For Both Frames

For general dimensions, see GV drawing
201-ASS-101

For installation information, see GV drawings
201-ASS-102
201-ASS-103
201-ASS-104

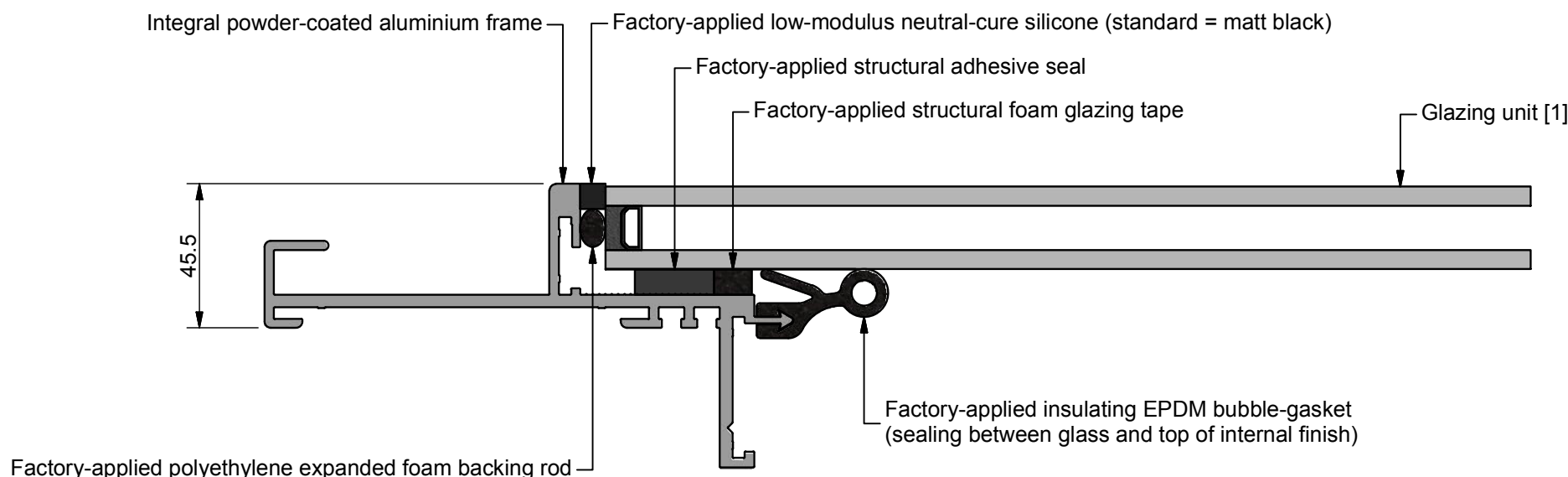

**GV Standard Pitchglaze MkII
Large Frame**

Used for glass between 44mm & 52.8mm in thickness
(typically triple glazed units)

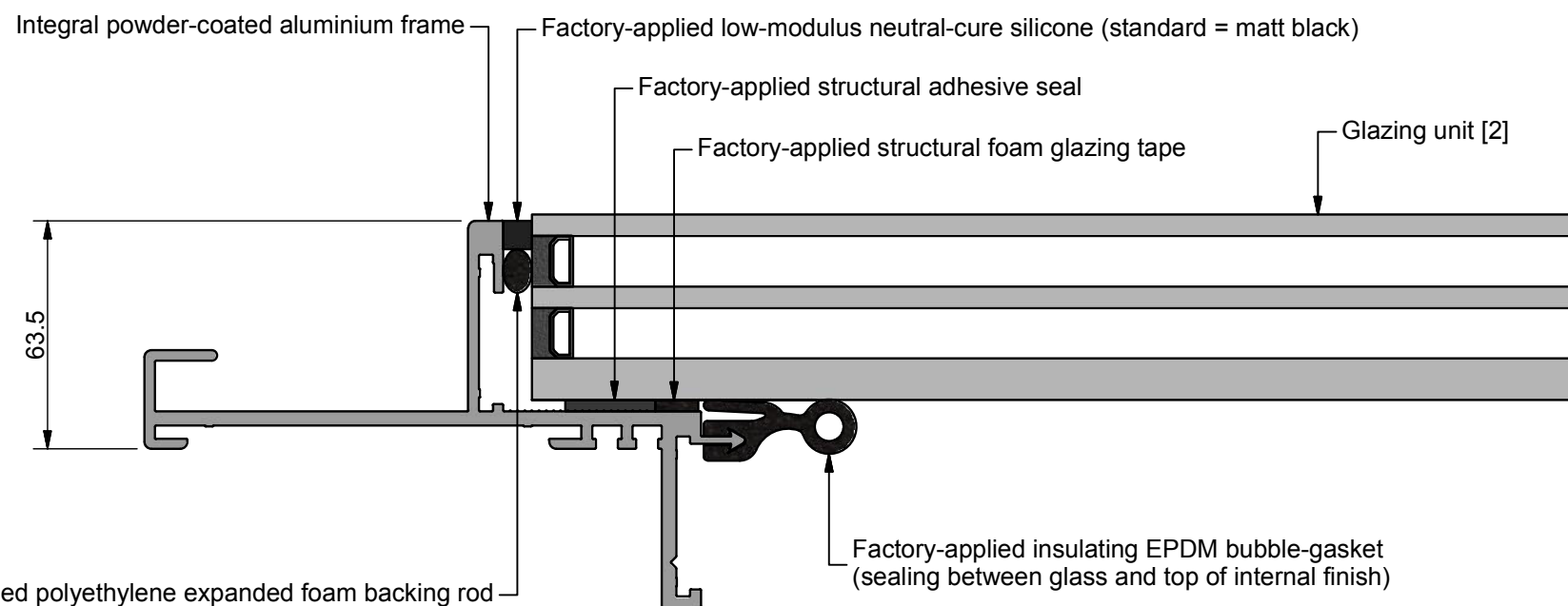

[1] Example glazing unit: Toughened double glazed unit
- 6mm HST toughened outer pane
- 16mm argon-filled cavity, black warm edge spacer
- 6mm HST toughened soft coat low-E inner pane

[2] Example glazing unit: HS laminated triple glazed unit
- 6mm HST toughened soft coat low-E outer pane
- 14mm argon-filled cavity, black warm edge spacer
- 6mm HST toughened soft coat low-E mid pane
- 14mm argon-filled cavity, black warm edge spacer
- 11.5mm HS-laminated inner pane



Saw Mills Road
Diss
Norfolk
IP22 4RG
Tel: +44 (0)333 8000 881
Fax: +44 (0)333 8000 882
Email: sales@glazingvision.co.uk
Website: www.glazingvision.co.uk

IT IS GLAZING VISION'S POLICY TO CONTINUOUSLY DEVELOP AND IMPROVE OUR PRODUCTS. WE THEREFORE RESERVE THE RIGHT TO MODIFY OR CHANGE THE DETAIL DESIGN AT OUR DISCRETION AND WITHOUT PRIOR NOTICE. THIS DRAWING IS COPYRIGHT AND THE SOLE PROPERTY OF GLAZING VISION LTD. THE DESIGNS/INFORMATION IT CONTAINS ARE PRIVATE AND CONFIDENTIAL. IT MUST NOT BE COPIED, EXHIBITED OR COMMUNICATED TO THIRD PARTIES FOR ANY PURPOSE OTHER THAN THAT FOR WHICH IT WAS ISSUED WITHOUT THE WRITTEN PERMISSION OF GLAZING VISION LTD.

Third angle projection unless otherwise noted.
Tolerances:
Whole numbers = ±1mm
One decimal place = ±0.5mm
Two decimal places = ±0.2mm
All angles 90±0.5 degrees unless specified
IF IN DOUBT - ASK! DO NOT SCALE
Supplier to deburr & remove sharp corners

Rev	Revision Description	Drawn/Date
-	INITIAL ISSUE	JSL 24/01/2018

Product: 201 - GV Standard Pitchglaze MkII		Checked By: HL
Description: Pitchglaze Components		
Materials: -	Drawn By: JSL	Check Date: 24/01/2018
Finish: -	Drawn Date: 24/01/2018	
Weight: N/A	Quantity: -	
Scale: NTS	Drawing No: 201-ASS-105	