

Section A-A TOP (Head)

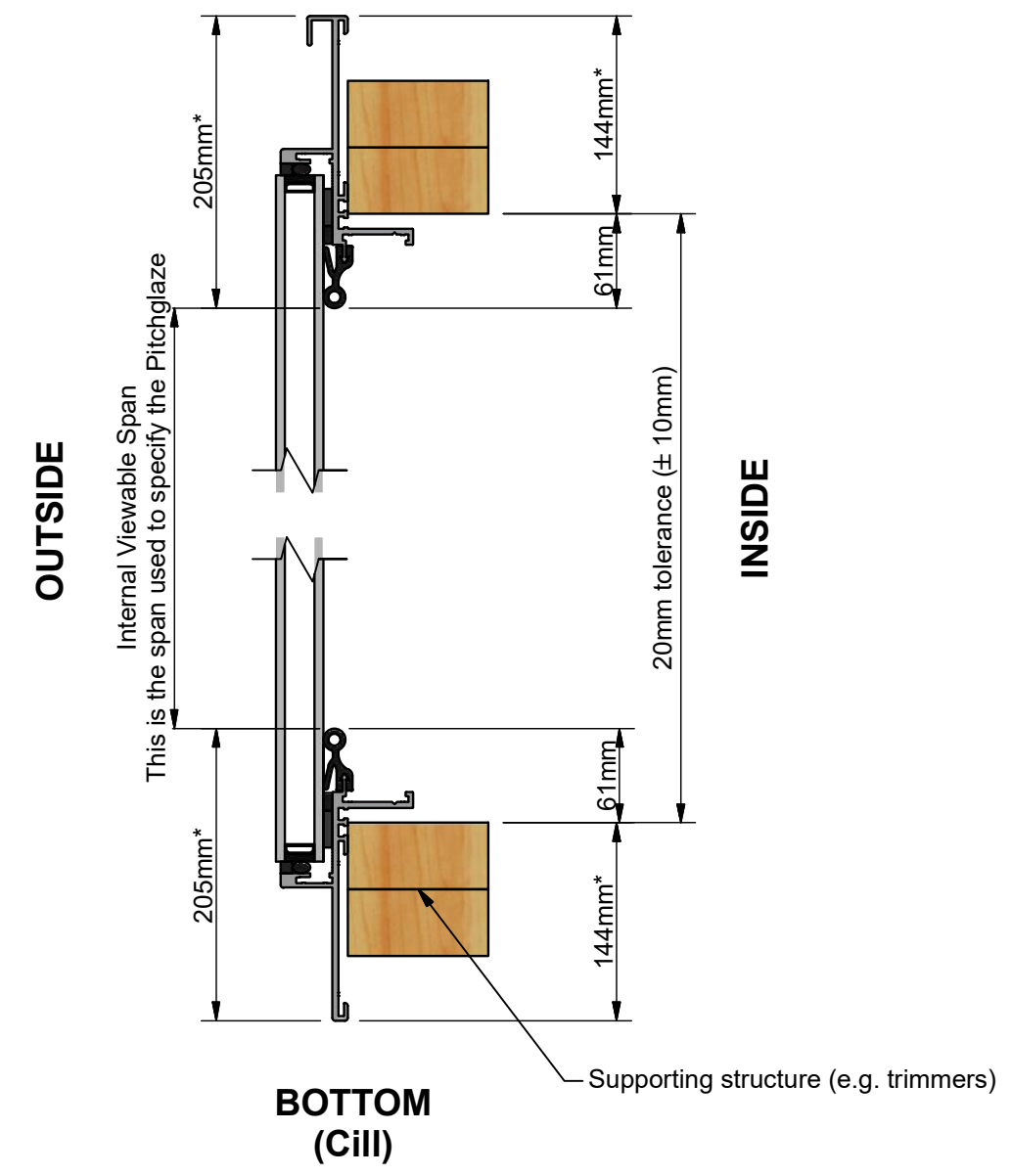

Section B-B OUTSIDE
Internal Viewable Width

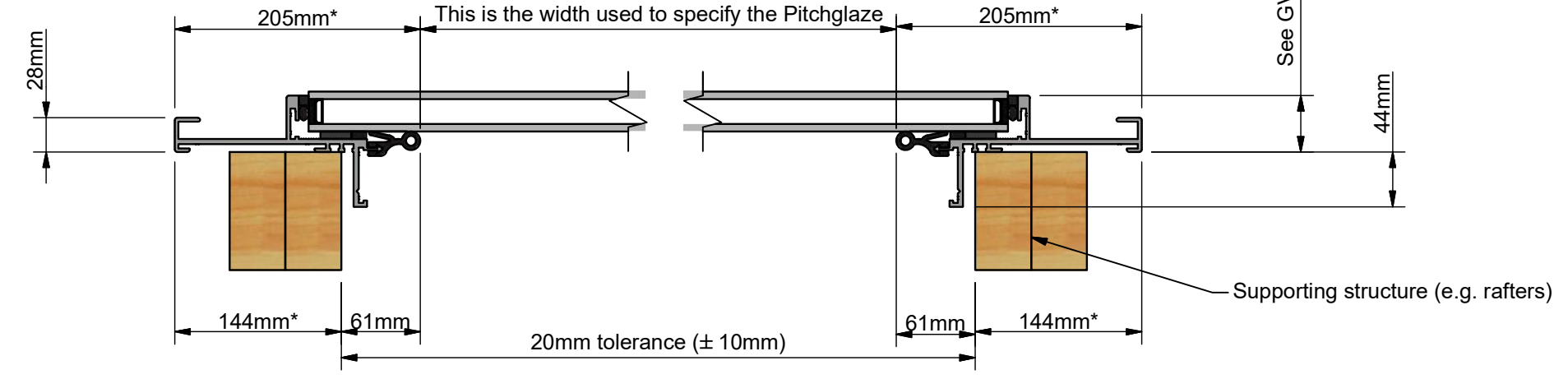

For installation information,
see GV drawings
201-ASS-102
201-ASS-103
201-ASS-104

* Value includes nominal 10mm tolerance

INSIDE

Rev	Revision Description	Drawn/Date
-	INITIAL ISSUE	JSL 24/01/2018
A	TOLERANCES ADDED TO ASTERISKED (*) VALUES	JSL 24/06/2019

Product: 201 - GV Standard Pitchglaze MkII		Checked By: HL
Description: General dimensions		
Materials: -	Drawn By: JSL	Check Date: 24/06/2019
Finish: -	Drawn Date: 24/01/2018	
Weight: N/A	Drawing No: 201-ASS-101	
Quantity: -		
Scale: NTS		