

# Keypad Connection (Alpro E0678)

This is a fixed installation using Glazing Vision's supplied keypad. All connections should be carried out by a competent person.

All cables supplied at 2 m, extendable to 10 m with appropriate cable.

All optional items must be specified at time of order.

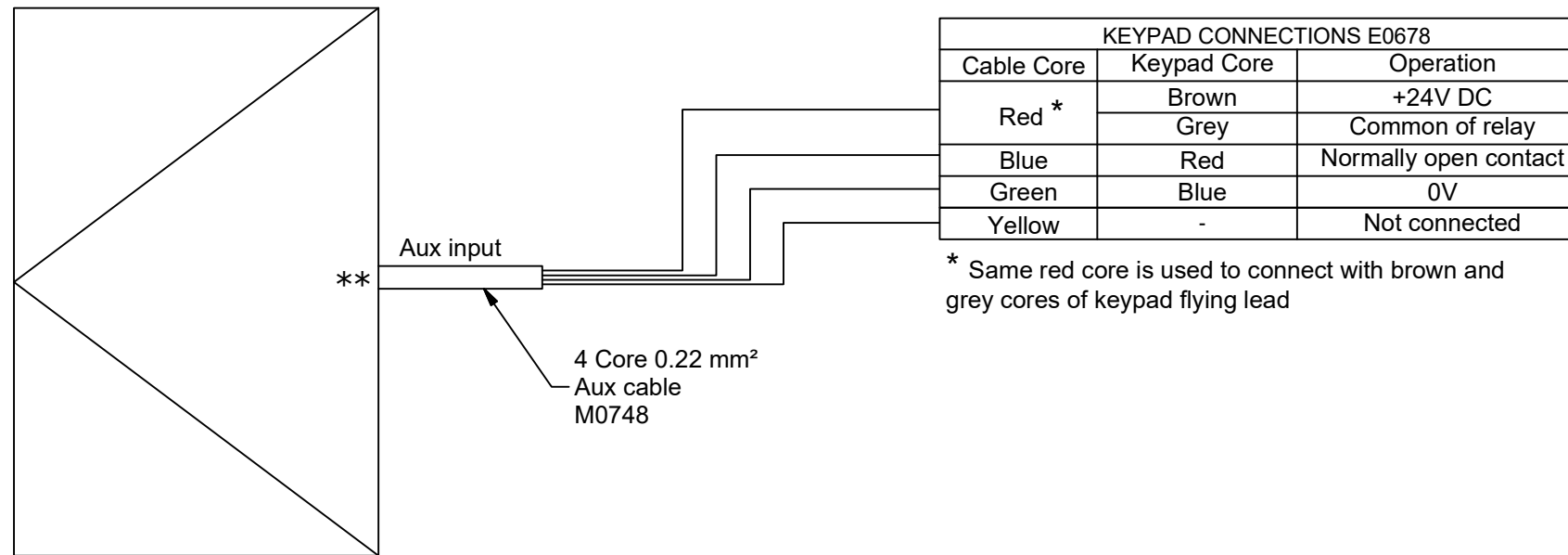

\*\*Cables exit from the underside of the product. See the upstand drawing for the exact exit position.

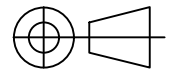

Third angle projection unless otherwise stated

THIS IS A STANDARD DRAWING. THE UNIT PURCHASED MAY VARY. THIS DRAWING DOES NOT INDICATE ACCURATE DIMENSIONS FOR ANY EXISTING STRUCTURAL COMPONENTS OR PRODUCTS.

DO NOT USE THIS DRAWING FOR ANY SITE LAYOUTS. ON-SITE PERSONNEL ARE RESPONSIBLE TO CONFIRM DRAWINGS VS SPECIFIC SITE CONDITIONS.

ESTIMATED WEIGHT N/A	SCALE Not to scale <small>(UNLESS OTHERWISE STATED)</small>
-------------------------	---

REVISION	DESCRIPTION	NAME/DATE
-	Initial Release	HL 09/Dec/2020

PROJECT Universal Controller MA0106 Wiring Diagrams	
TITLE / DESCRIPTION Keypad Connection (Alpro E0678)	CHECKED MJM
DRAWING NO. 100-SDD-UK-011	SHEET 1 OF 1