

Section B-B (Scale 1 : 2)

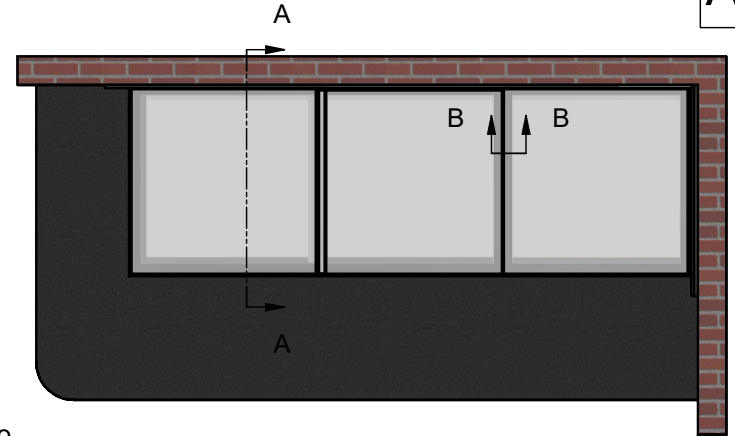
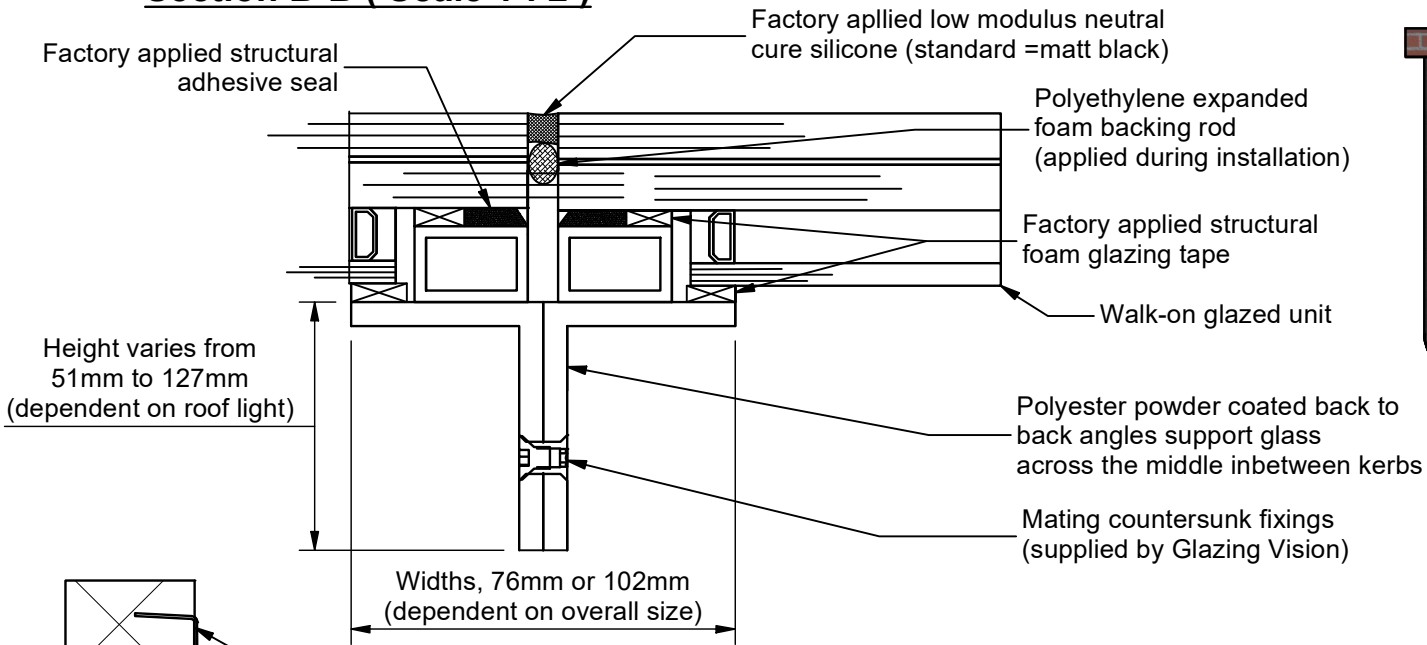

Note: This is a standard reference drawing which includes both wall and kerb mounting details to illustrate the possible configurations for the flushglaze range. It is not an order specific drawing and therefore does not reflect your specific order dimensions or configuration. Ensure you check your order confirmation meets the specifics of your order before signing.

Refer to 402-ASS-008 for wall mount detail

Refer to 402-ASS-003 for kerb mount detail

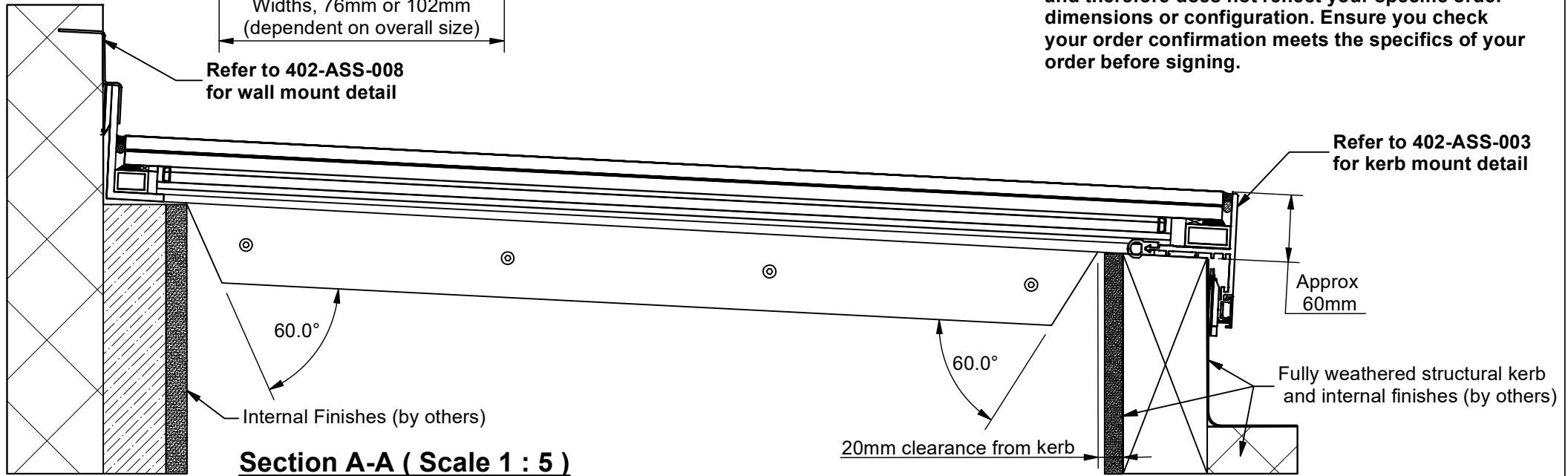

Section A-A (Scale 1 : 5)



Saw Mills Road
Diss
Norfolk
IP22 4RG
Tel: +44 (0)333 8000 881
Fax: +44 (0)333 8000 882
Email: sales@glazingvision.co.uk
Website: www.glazingvision.co.uk

IT IS GLAZING VISION'S POLICY TO CONTINUOUSLY DEVELOP AND IMPROVE OUR PRODUCTS. WE THEREFORE RESERVE THE RIGHT TO MODIFY OR CHANGE THE DETAIL DESIGN AT OUR DISCRETION AND WITHOUT PRIOR NOTICE. THIS DRAWING IS COPYRIGHT AND THE SOLE PROPERTY OF GLAZING VISION LTD. THE DESIGNS/INFORMATION IT CONTAINS ARE PRIVATE AND CONFIDENTIAL. IT MUST NOT BE COPIED, EXHIBITED OR COMMUNICATED TO THIRD PARTIES FOR ANY PURPOSE OTHER THAN THAT FOR WHICH IT WAS ISSUED WITHOUT THE WRITTEN PERMISSION OF GLAZING VISION LTD.

Third angle projection unless otherwise noted.
Tolerances:
Whole numbers = ±1mm
One decimal place = ±0.5mm
Two decimal places = ±0.2mm
All angles 90±0.5 degrees unless specified
IF IN DOUBT - ASK! DO NOT SCALE
Supplier to deburr & remove sharp corners

Rev	Revision Description	Drawn/Date
P	Description changed to suit data sheet	SW 11.04.16
Q	Kerb reference drawing number corrected	RJ 11.01.23

Product: 402-Flushglaze		Checked By:
Description: Walk-on Flushglaze multipart		
Materials: N/A		Check Date:
Finish: N/A		
Weight: N/A		Drawn By: SW
Quantity: N/A		Drawn Date: 16.07.2015
Scale: 1:5, 1:2 & 1:40 @ A4		Drawing No: 402-ASS-016