

GV Standard Pyramid

Operation and Maintenance Manual

GLAZING VISION

Contents

Section Description	Page
Contents and introduction	2
Controls and operation electric pyramid	3
Controls and operation manual pyramid	4
Manual override electric pyramid	4
Glazing Vision remote control	6
Cleaning the Pyramid	7
General maintenance and safety	7
Troubleshooting electric pyramid	8
Standard glass specification and breakage	9
COSHH and safe disposal	10
Warranty information	10

Introduction

Thank you for purchasing a Glazing Vision Pyramid (*Figure 1*). We hope that it gives you many years of service. The Pyramid is available as a fixed or opening rooflight both of which are covered by this manual. Should you have any queries beyond this manual please do not hesitate to contact us.

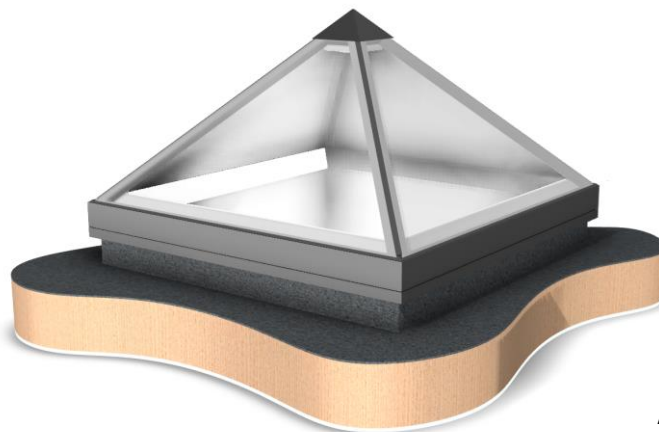

Figure 1 – Fixed pyramid

Controls and Operation Electric Pyramid

Control Switch:

The standard operation is via the supplied wall switch (*Figure 2*) and can be operated using two different methods as explained below:

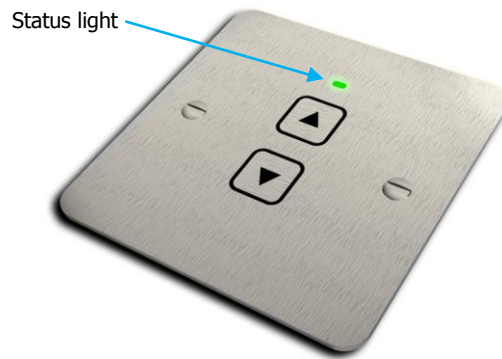

Figure 2 –Wall mounted control switch

1. **'One touch' operation** – Press and release the control switch in either the up or down (open/closed) direction as required. The rooflight will open or close fully. Press the control again to stop the rooflight if you want it partially open or closed.
2. **Conventional 'hold' operation** – Press and hold the control switch until the rooflight has reached the position you want, When you release the switch the rooflight will stop in that position. If you continue to press the switch the rooflight will stop when it becomes either fully open or closed.

Status Light:

The status light will illuminate green if the rooflight is working normally. If the status light displays another colour please refer to the troubleshooting section.

Remote Control (Optional):

The remote control (*Figure 3*) unit functions in the same way as the control switch but allows you to open and close your rooflight from a short range. The remote control is powered by two AA batteries.

To replace the batteries, remove the small hex screws found on the rear of the remote to allow access inside (*please note there is a free end wire antenna coiled within the remote*).



Figure 3 – Remote control

Building Management (Optional):

The VisionVent can be connected to building management systems. Please contact Glazing Vision Ltd for further details if required.

Rain Sensor Operation (Optional):

The rain sensor (*Figure 4*) automatically closes the rooflight when it rains. If moisture is detected on the rain sensor during the opening cycle, a special built in heater activates for 60 seconds to evaporate standing water. If after 60 seconds water is still detected, the rooflight will close. This feature enables the rooflight to differentiate between rain and standing water / morning dew.



Figure 4 –Rain sensor

Operation of the Manual Pyramid**Opening and closing the manual Pyramid:**

The vent is opened and closed by turning the hook eye on the end of the telescopic spindle (*Figure 5*) with the supplied crank handle. When viewed from below, a clockwise rotation opens the vent.



Figure 5 – Opening / closing spindle

Manual Override Electric Pyramid

The electric pyramid is equipped with a manual override function. This is an emergency fail safe should the unit not open or close for any reason. The override holes are located on the inside of the unit approximately 320mm from the opening edge (*Figure 6*).

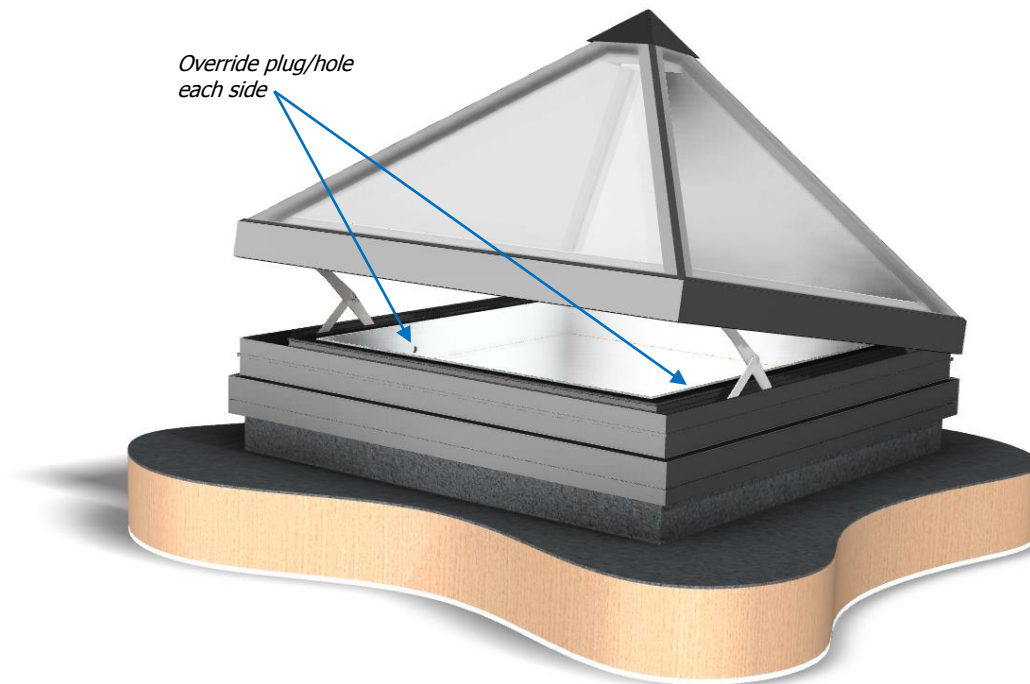

Figure 6 – Manual override location

To override the electric mechanism, the cover caps for the override holes should be removed (these are just press fit plugs); insert a 5mm Allen key (supplied with the rooflight) through the hole and engage with the cap head bolts (*Figure 7*).

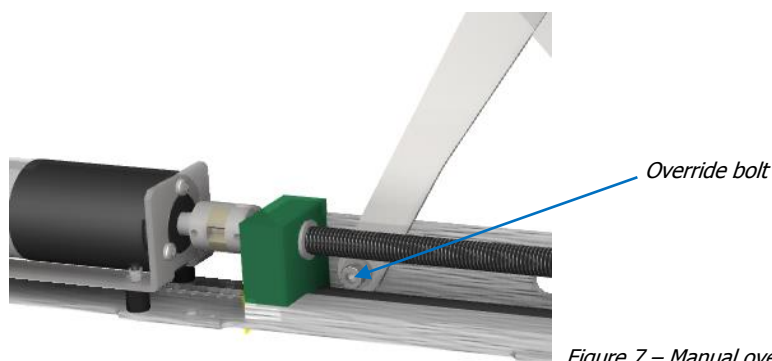

Figure 7 – Manual override bolt location

Support the weight of the lid and unscrew the bolts by turning anti-clockwise. Once both override bolts have been removed the main link arm will be free to move within the pyramid's slide channel. With both override bolts removed the lid can either be opened approximately 130mm at the opening edge or fully closed. The unit should be water tight however it will not be mechanically locked.

Glazing Vision Remote Control

As previously stated, the remote control is an optional item only available for use with electric versions of the Pyramid.

In order to preserve the battery, the remote control will switch itself off after a brief period of inactivity. It will switch itself on when either of the buttons on the remote control are pressed.

Any given VisionVent will pair with a maximum of four remote controls. This section explains how to pair a remote control device to your VisionVent, how to delete a remote control device from your VisionVent, and how to clear the memory of the VisionVent to delete all remote control devices.



To add or delete a remote control ensure that the rooflight is fully closed. Press & hold the CLOSE (Down arrow) button on the wall-mounted switch, then press & hold the OPEN (Up arrow) button too; as soon as the LED starts flashing, release both buttons. The LED will now flash red and blue alternately for 15 seconds.



Figure 8 – Wall mounted control switch

Press the OPEN button on the remote control during the 15 second period. The LED will stop flashing if pairing is successful. If the LED continues to flash this means that either the remote is already paired to this VisionVent, the memory is full (ie the VisionVent is already paired with four remote controls) or the remote is faulty.

To delete a remote:

Press the CLOSE button on the remote control during the 15 second period. The LED will stop flashing if deletion is successful. If the LED continues to flash this means that the remote is not paired to this VisionVent and therefore cannot be deleted.

To clear the VisionVent memory:

Press and hold the CLOSE button of the remote control for 2 seconds during the 15 second period. This will delete all other remote controls from memory and will add this device as the sole remote control paired with the rooflight.

Cleaning the Pyramid

Due to the Pyramid's unique bonding method and the pitch of the glazing, there will be no water ponding on the glass. Any standard glass-cleaning product can be used to clean the glass unit. However, take care not to use abrasive materials or cleaners as this may affect the unit and its finish. The framework of the unit can be cleaned using warm soapy water with a soft lint free cloth.

General Maintenance & Safety

To keep the Pyramid in good condition there are a few basic points that should be observed:

- Do not place anything on the pyramid or stand on the unit.
- Keep the frame clear of general dirt and debris build up.
- Do not allow unauthorised persons (e.g. Children) to operate the rooflight as this may lead to injury or damage to the product.

Troubleshooting Electric Pyramid

The Pyramid control board monitors the operation of the vent. If a fault is detected, the board will disable the vent to prevent possible damage. Fault and standard conditions are indicated by the status light on the control switch (*Figure 12*). The following table shows the various status light displays and their meanings:

Status light shown	Meaning
Continuous Green	Displayed whilst rooflight is in motion with no faults present. If rooflight is one-touch opened or closed LED will remain lit until motion stops.
Intermittent Green	Flashes whilst rooflight closes due to rain sensor. Flashing will stop when motion stops.
Continuous Blue	Indicates an IO fault, i.e. a mechanism timing fault. LED remains lit and control switch is disabled until control board is reset.
Intermittent Blue	Indicates an overcurrent or undercurrent condition. Flashes and control switch is disabled until control board is reset.
Intermittent Red	This status light is used only on vent & access models. Intermittent red will be displayed while the mechanisms are moving between the standard open and the maintenance position.
Continuous Red	This status light is used only on vent & access models. Continuous red is displayed while the rooflight is in the access position.

If a fault occurs please refer to the table below. Some faults with the unit may be easily corrected without the need for a site engineer. However, if you are unsure please contact Glazing Vision Ltd. Some faults can be cleared by resetting the board. To reset the system switch off mains power briefly then switch the power back on again. In some cases the Pyramid will now operate as normal. In other cases the fault will re-occur, if so, please contact Glazing Vision Ltd.

Problem	Possible Cause	Action
Overcurrent Fault (Blue light flashing)	Is there a mechanical obstruction preventing the lid from moving?	If possible, look at the mechanisms and remove any obvious obstructions.
	Is the lid frozen to the base?	Attempt to open the vent once ice has melted.
	Has the vent been left inactive for a long period (a month or longer)?	An overcurrent fault is likely after a long period of inactivity. Reset vent and try again.
Input/output Fault (Blue light continuous)	There is a problem with one of the mechanisms.	Disable vent by switching off the power. Contact Glazing Vision for further assistance.
VisionVent closes for no apparent reason.	This should only occur if a rain sensor is fitted and indicates that the sensor head is dirty or still wet.	Open VisionVent and isolate power supply, then clean the rain sensor head.

Standard Glass Specification and Breakage Instructions

Glass Specification

The standard glass used within the Pyramid comprises a 6mm HST toughened outer pane, a 20mm warm edge spacer argon filled black silicone sealed cavity and a 6mm HST soft coat Low E toughened inner pane. However, various options are available at time of order. If specific data is required for the glazing please contact Glazing Vision for a glass data sheet for the specification installed within your rooflight.

Breakage Instructions

Should the double glazed unit break for any reason, due to the unique method of bonding the glass unit into the frame, a new lid (entire rooflight in fixed pyramid's case) would need to be supplied. Glass breakage is not covered by the product warranty unless the breakage is a direct result of Glazing Vision Limited or its product failing. In the event of the glass being damaged please contact Glazing Vision for assistance.

COSHH and Safe Disposal

There are no hazardous materials used in the construction of the Pyramid. Wherever possible when disposing of the Pyramid recycle as much as possible. Do not burn any plastic materials. The following materials are used throughout the VisionVent:

Framework

- Aluminium extrusion
- Aluminium corner brackets
- Stainless steel fixings
- Stainless steel slider strips
- Low modulus silicone
- PVC foam tape
- Acrylic adhesive (corner joints)
- Polyester powder coated finish
- Closed cell PIR foam insulation
- EPDM rubber gaskets
- Polyamide thermal break strips
- Polyethylene backing rod
- Toughened glass panes
- Warm edge spacer bar
- White polypropylene (PP) cover plate
- Grey polyvinyl chloride (PVC) cover plate (integrated unit)

Mechanisms and control

- Stainless steel fixings
- Stainless steel base plate
- Stainless steel side guide plate
- Stainless steel link arms
- Stainless steel lead screw
- Stainless steel coupling
- Anodised aluminium slider support
- Oilon lead screw block
- Nylon end blocks
- Nylon sliding shoe
- Printed circuit boards (PCBs)
- SPST rocker switch
- Copper wiring
- Electric motor
- Limit switches
- Standard insulated spade terminals
- Stainless steel push switch (access)
- HIPS electronics enclosure
- 626Z Bearing
- Brass telescopic spindle (manual)

Product Warranty

A warranty document will be provided with the rooflight. If this is misplaced it can be found at www.glazingvision.co.uk/resources/warranties/.